

HEAT STAR

CONSTRUCTION HEATERS

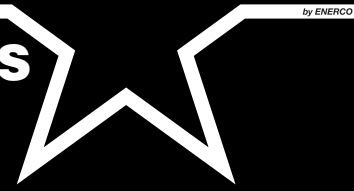

REAL. TOUGH. HEAT.



REAL. TOUGH. HEAT.

TABLE OF CONTENTS

PROPANE VAPORIZATION GUIDE

Lbs. of Propane in Cylinder	Maximum Continuous BTU Per Hour at Various Temperatures		
	0°	20°	40°
100	113,000	167,000	214,000
90	104,000	152,000	200,000
80	94,000	137,000	180,000
70	83,000	122,000	160,000
60	75,000	109,000	140,000
50	64,000	94,000	125,000
40	55,000	79,000	105,000
30	45,000	66,000	85,000
20	36,000	51,000	69,000
10	28,000	38,000	49,000

ICON GUIDE



Easy repairs
Tech service: 1-866-447-2194



Heavy-duty



Easy-grip handle



Indoor safe

Description

Page

Indirect-Fired Heaters & Accessories

4-5

Direct-Fired Heaters & Accessories

6

Forced Air Diesel & Kerosene Heaters

7

Dual Fuel Direct-Fired Heaters & Accessories

8

Convection Heaters

9

Box Heaters & Accessories

10-11

Oil-Fired Radiant Heaters

12

Portable Radiant Heaters

13

Forced Air Propane Heaters

14-15

Electric & Vent Free

16

Handheld Torches

17

Tank Top Heaters

17

Garage & Unit Heaters

18-19

FAK/LP Replacement Parts

20-21

Hoses, Fittings & Regulators

22-23

INDIRECT-FIRED HEATERS



HSP70ID

HSP100ID

HSP200ID

HSP300ID

**KEROSENE
JP8 (JET A FUEL)
#1 & 2 DIESEL FUEL
#1 & 2 FUEL OIL**

FEATURES:

- Heat Exchanger to Keep Exhaust Gas and Heated Air Separate
- Large Capacity Diesel Fuel Tanks Provide Hours of Continuous Operation
- Powerful Fans Ensure High Static Pressure
- Long-Life Stainless Steel Combustion Chamber
- Electronic Flame Control
- Water Resistant Flame Control Box
- Automatic Safety and Control Devices
- Optional Thermostat Available for Constant Temperature Control
- Durable Powder Coated Finish
- Heavy-Duty Duct Adapter Available
- UL Certified



	HSP70ID	HSP100ID	HSP200ID	HSP300ID
Stock number	F105105	F105110	F105115	F105120
Input BTU/hr	70,000	122,000	180,000	285,000
Heating Area (Sq. Ft.)	1,750	3,050	4,625	7,125
CFM output	910	1060	1060	1950
Tank capacity (GL/hr)	11.6	17	17	27.7
Fuel consumption: GL/hr	0.55	0.86	1.27	2.02
Power required	120V 3 Amp	120V 7.5 Amp	120V 13 Amp	120V 11.4 Amp
Single duct diameter	12"	12" or 14"	14"	16"
Maximum duct length	25'	25'	50'	100'
Shipping size LxWxH	47.2" x 16.5" x 21.7"	47.2" x 19.3" x 41"	51" x 19.3" x 41"	63" x 24.4" x 47.2"
Shipping weight	81.6	167	185.2	271

ACCESSORIES

	HSP70ID	HSP100ID	HSP200ID	HSP300ID
Single duct adapter	F105107 (12")	F105104 (12") F105111 (14")	F105111 (14")	F105121 (16")
Dual duct adapter	N/A	F105117 (12")	F105117 (12")	F105122
Flex heat duct 12" x 25'	F150040	F150040	F150040 (use w/dual duct)	N/A
Flex heat duct 14" x 25'	N/A	F150043	F150043	N/A
Flex heat duct 16" x 25'	N/A	N/A	N/A	F150050
Air Recycle Kit	N/A	F105112	F105112	F105123
Remote analog thermostat	F105108 (33')	F105108 (33')	F105108 (33')	F105108 (33')
Digital thermostat	F105106 (33')	F105106 (33')	F105106 (33')	F105106 (33')
Heated fuel filter	F105109	Standard	Standard	Standard

FEATURES:

- Heavy-Duty Frame
- Lift Bracket
- Large Fuel Tank
- UL Certified
- Single or Dual Ducts
- Industry Leading Automatic Electronic Burner Control
- Designed for "Once A Year" Maintenance

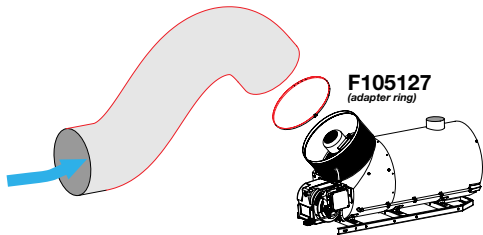

(Air Recirculating Kit)



	HSP500ID-A	HSP400ID-G
Stock number	F105125	F105135
Input BTU/hr	400,000/MAX 500,000	399,000
Heating Area (Sq. Ft.)	10,000	9,875
CFM output/Static pressure	4032/1.08" WC	4032/1.08" WC
Heated fuel filter	Option	Option
Tank capacity (GL/hr)	46	N/A
Fuel consumption:	3.6 GL/hr	18.53 lb./hr (LP) 0.4 MCF (NG)
Power required	120V/60Hz 13.4 Amp	120V/60Hz 13.4 Amp
Single duct diameter	16"	16"
Maximum duct length	100'	100'
Shipping size LxWxH	64" x 27" x 60"	68" x 27" x 60"
Shipping weight	573	473
Fuel type	Kerosene, JP8 (Jet A Fuel), #1 & #2 Diesel Fuel, #1 & #2 Fuel Oil	NG/LP

ACCESSORIES

	HSP500ID-A	HSP400ID-G
Single duct adapter	F105126 (16")	F105126 (16")
Dual duct adapter	Standard - Dual 12" duct adapter attached	Standard - Dual 12" duct adapter attached
Flex heat duct 12" x 25'	F150040	F150040
Flex heat duct 16" x 25'	F150050	F150050
Remote analog thermostat	F105108 (33')	F105108 (33')
Digital thermostat	F105106 (33')	F105106 (33')
Heated fuel filter	Standard	Standard
Air Recycle System	F105127 Adapter Ring 24"x25" duct & 24" clamp	F105127 Adapter Ring 24"x25" duct & 24" clamp

DIRECT FIRED HEATERS

FEATURES:

- Heavy-Duty Construction - Built-In Oil Burner - 115 V 60Hz
- Flame Safety/Overheat Safety Shutoff
- Electronic Flame Control System
- Continuous Ignition
- Stainless Steel Heat Exchanger
- High Output Fan
- Pre-Heated Oil Filter (HS6000DF only) - Pre-Purge And Ventilation Cycles
- Optional Remote Thermostat
- CSA Certified

Model #	Description
F151089	HS3500DF 360,000 BTU/HR
F151100	HS6000DF 610,000 BTU/HR



SPECIFICATIONS:	HS3500DF	HS6000DF
Stock Number	F151089	F151100
Output (BTU/HR)	360,000	610,000
Heating Area (SQ. FT.)	9,400/75,000	14,250/114,000
CFM Output	1,800	2,800
Fuel Consumption (GAL - H/HR-L/HR)	2.75/10.41	4.4/16.65
Tank Capacity (GAL-L)	27.7/104	35.6/134
Tires/Wheels	10" Pneumatic	10" Pneumatic
Operating Hours On Full Tank	9.5	8.6
Shipping Size (L x W x H)	66" x 27" x 39"	76" x 27" x 39"
Shipping Weight	227 lbs.	247 lbs.
Multi-Fuel (No. 1 Or No. 2 Diesel Oil, Kerosene, JP-8 Or Jet A)	Yes	Yes
Optional Remote Thermostat	F150035 - 32' 8" Cord	F150035 - 32' 8" Cord

FORCED AIR DIESEL & KEROSENE

Model #	Description
F170250	HS50K 50,000 BTU/HR
F170275	HS75KT 75,000BTU/HR

FEATURES:

- Heavy-Duty Construction - Illuminated On-Off Switch - 115 V 60Hz
- 25% Heavier Gauge Steel for Durability
- Motor 25% More Horsepower
- Flame Safety/Overheat Safety Shutoff
- Enclosed Motor - Fuel Gauge
- Continuous Ignition
- Cord Wrap (HS75KT only) - High Output Fan
- Larger "Glove-Friendly" Controls
- CSA Certified



LARGE JOBSITES

Model #	Description
F170325	HS125KT 125,000 BTU/HR
F170375	HS175KT 175,000 BRU/HR
F170380	HS210KT 210,000 BTU/HR

FEATURES:

- Heavy-Duty Construction - Illuminated On-Off Switch -115 V 60Hz
- 25% Heavier Gauge Steel for Durability
- Motor 25% More Horsepower
- Flame Safety/Overheat Safety Shutoff
- Enclosed Motor - Fuel Gauge - High Output Fan
- Continuous Ignition
- Large Heavy-Duty Handles w/cord wrap
- 10" Solid foam filled tires
- Larger "Glove-Friendly" Controls
- CSA Certified



Part #	HS50K	HS75KT	HS125KT	HS175KT	HS210KT
Model #	F170250	F170275	F170325	F170375	F170380
Output (BTU/HR)	50,000	75,000	125,000	175,000	210,000
Heating Area (SQ. FT.)	1,200	1,750	3,000	4,250	6,000
CFM Output	165	240	275	400	400
Fuel Consumption (GAL H/HR-L/HR)	.38/1.43	.56/2.11	.77/2.91	1.15/4.35	1.60/6.05
Tank Capacity (GAL-L)	4/15	6/22	14/52	14/52	14/52
Tires/Wheels	NA	NA	Solid Foam Filled	Solid Foam Filled	Solid Foam Filled
Operating Hours On Full Tank	11	11	15	10	8
Shipping Size	32" x 14" x 14.5"	32" x 14.25" x 17"	42" x 18" x 22"	42" x 18" x 22"	42" x 18" x 22"
Weight	43 lbs.	43 lbs.	74 lbs.	81 lbs.	87 lbs.
Multi-Fuel (No. 1 Or No. 2 Diesel Oil, Kerosene, JP-8 Or Jet A)	Yes	Yes	Yes	Yes	Yes



DUAL-FUEL (NG/LP) HEATERS

FEATURES:

- Dual Fuel Natural Gas/Propane
- Simple Gas Valve Switch to Change Fuels and Safety Locking Device to Keep Valve in Set Position
- 20" Duct-Ductable up to 50'
- Clean Burn with Very Low (CO, and NOx)
- Approved for Construction, Greenhouses and Brooders
- Duct and Duct Adapter Optional
- Remote Thermostat with 30' Cord Optional
- Ventilation Only Mode (Fan can be Operated when Burner is Off)
- CSA Certified

Model #	Description
F151200	HS4000NG/LP 400,000 BTU/HR



ACCESSORIES

Stock #	Description
F150035	Thermostat Cord 32' 8"
F151225	20' Diameter Duct Adapter
F151084	20" X 25' Duct



Shown with optional Duct and Duct Adapter

SPECIFICATIONS

BTU/HR Output	400,000
Electric	120 V
Output CFM	4,120
Running Amps	8.5 Amps
Weight	192 lbs.
Size (L x W x H)	56" x 24" x 33"

Model #	Description	Heats Up To	Operates Up To
F170470	HS80CVX - 30,000-80,000 BTU/HR	1,900 Sq. Ft.	14 hrs. on a 20 lb. tank
F170473	HS100NG - 100,000 BTU/HR	2,500 Sq. Ft.	Natural Gas
F170475	HS200CVX - 75,000-200,000 BTU/HR	4,700 Sq. Ft.	29 hrs. on a 100 lb. tank

FEATURES:

- HS80CVX Heats Approx. 2,000 Sq. Ft. and Runs Up to 14 Hrs. on 20 Lb. Tank (Low)
- HS200CVX Heats Approx. 5,000 Sq. Ft. and Runs Up to 29 Hrs. on 100 Lb. Tank (Low)
- Piezo Push-Button Igniter
- Telescoping Chamber for Reduced Ship Cube/Retail Space
- Instant Locking Chamber for Easy Assembly
- 20' Hose and Regulator Included
- Certified



SPECIFICATIONS:	HS80CVX	HS100NG	HS200CVX
Stock Number	F170470	F170473	F170475
Output (BTU/HR)	30,000-80,000	100,000	75,000-200,000
Heating Area (SQ. FT.)	2,000	2,500	5,000
Fuel	Propane Gas	Natural Gas	Propane Gas
Propane Consumption (lbs/hr)	1.4 to 3.7	-	3.5 to 9.3
Pressure Regulator Settings	10 PSI	5" W.C.	10 PSI
Flame Safety*	Thermocouple Operated Gas Valve	Thermocouple Operated Gas Valve	Thermocouple Operated Gas Valve
Standing Pilot	Yes	Yes	Yes
Ignition	Piezo	Piezo	Piezo
Power Required	None	None	None
Hose 20ft.	3/8" I.D. w/Regulator and POL	NA w/Natural Gas	1/4" I.D. w/Regulator and POL
POL/Excess Flow Check Valve	Yes	NA w/Natural Gas	Yes
Shipping Size (L x W x H)	15.25" x 18.25" x 21.75"	15.25" x 18.25" x 21.75"	18.25" x 15" x 27.5"
Net Weight (Includes Hose/Regulator/POL Assembly)	19 lbs.	19 lbs.	25 lbs.
Shipping Weight	21 lbs.	21 lbs.	27 lbs.
Shipping Cube	3.50	3.50	4.36

NOMAD

TENT & CONSTRUCTION HEATERS

STANDARD FEATURES:

- Whisper Quiet Operation
- Multi-Rate Heat Settings - High/Low
- Dual Fuel (NG/LP)
- Higher CFM
- Easy Reset High Limit Switch
- Choose Rate and Fuel with Flip of a Switch
- Flexible Diffuser Connector System



Model Number	HS250TC	HS190TC	HS115TC
Item number	F109120	F109110	F109100
BTU's ('000) Low Setting	172 NG / 181 LP	129 NG / 127 LP	77 NG / 81 LP
BTU's ('000) High Setting	249 NG / 249 LP	184 NG / 190 LP	108 NG / 111 LP
Heating Area (SQ. FT.)	6250	4750	2875
Electric	115V 9.1 amps	115V 5.5 amps	115V 3.6 amps
L x W x H Dimensions	35.8" x 20.3" x 34.8"	35.8" x 20.3" x 34.8"	30" x 15" x 23.8"
Weight	165 lbs.	159 lbs.	91 lbs.
Thermostat	Thermostat with 20' Cord (standard)	Thermostat with 20' Cord (standard)	Thermostat with 20' Cord (standard)
Ignition	Spark	Spark	Spark
Gas Hose	15' Hose & Regulator (standard)	15' Hose & Regulator (standard)	15' Hose & Regulator (standard)



BOX HEATER ACCESSORIES

Diffuser Kits	Item number	Description
Diffuser kit for HS115TC	F109105	12" diameter, comes with (1) 12" connector ring
Diffuser kit for HS190TC or HS250TC	F109115	16" diameter, comes with (1) 16" connector ring
Adapter Rings		
Duct adapter ring for HS115TC	F109106	12" diameter connector ring
Duct adapter ring for HS190TC or HS250TC	F109116	16" diameter connector ring
Ducts		
Short duct for HS115TC	F109107	30" siliconized flex duct, 12" diameter
Short duct for HS190TC or HS250TC	F109117	30" siliconized flex duct, 16" diameter
Long duct for HS115TC	F109108	10' siliconized flex duct, 12" diameter
Long duct for HS190TC or HS250TC	F109118	10' siliconized flex duct, 16" diameter
Storage		
Painted steel storage box for HS190TC/HS250TC	F109119	31 1/4" x 20 1/4" x 10" box w/lock hasp

Accessory set up options:	
Option 1	Connect nothing, run heater by itself
Option 2	Adapter ring - 30" short duct - adapter ring - diffuser
Option 3	Adapter ring - 10' long duct
Option 4	Adapter ring - 10' long duct - adapter ring - diffuser
Option 5	Adapter ring - 30" short duct

12" FITS HS115TC

16" FITS HS190TC & HS250TC

12" DUCT ADAPTER (F109106)

12" X 30" TRANSITION DUCT (F109107)

16" DUCT ADAPTER (F109116)

16" X 30" TRANSITION DUCT (F109117)

12" X 10' FLEXIBLE DUCT (F109108)

12" UNIVERSAL DIFFUSER (F109105)

12" X 10' FLEXIBLE DUCT (F109108)

16" UNIVERSAL DIFFUSER (F109115)

STORAGE BOX ONLY FITS HS190TC & HS250TC

OIL-FIRED RADIANT HEATERS

FEATURES:

- Electronically Controlled Burner Assembly Enhances Fuel Economy
- Radiant Heat with No Air Movement
- Heavy-Duty Construction
- Low Noise Level
- Odor Free
- Operates Using Kerosene, JP8 (Jet A Fuel), Filtered #1 and #2 Diesel, and #1 and #2 Fuel Oil
- Shock Proof Fuel Tank
- Large Capacity Fuel Tanks
- Adjustable Handle (HSP150R & HSP125R)
- Lift Bracket
- Tip Switch on Board for Safety
- Floor Heat Shield Attached on HSP150R & HSP125R



DUAL STAGE BURNER HI/LOW SETTINGS



RADIANT HEAT

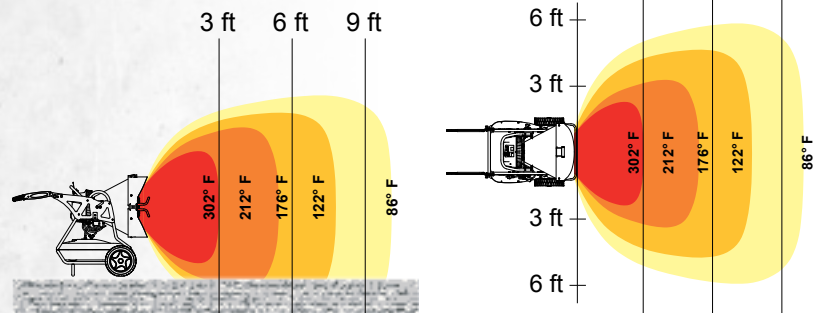

	HSP60R	HSP125R	HSP150R
Stock number	F105155	F105159	F105160
Input BTU/hr	58,000	95,000/126,000	102,000/146,900
Heating Area (Sq. Ft.)	1,450	2,375/3,150	3,673
Burner Surface	12"	23"	23"
Heated fuel filter	F105114	F105114	F105114
Tank capacity (GL/hr)	2.9	14	14
Fuel consumption: GL/hr	0.41 GL/hr	0.72 (Lo) / 1.06 (Hi)	0.72 (Lo) / 1.06 (Hi)
Power required	120V/60Hz - 1.25 Amp	120V/60Hz - 1.25 Amp	120V/60Hz - 1.25 Amp
Remote analog thermostat	F105108 (33')	F105108 (33')	F105108 (33')
Shipping size LxWxH	24" x 15" x 23"	40.5" x 29.5" x 46.5"	41" x 30" x 47"
Shipping weight	21	148	149
Fuel type	Kerosene, JP8 (Jet A Fuel), #1 & #2 Diesel Fuel, #1 & #2 Fuel Oil	Kerosene, JP8 (Jet A Fuel), #1 & #2 Diesel Fuel, #1 & #2 Fuel Oil	Kerosene, JP8 (Jet A Fuel), #1 & #2 Diesel Fuel, #1 & #2 Fuel Oil

PORTABLE RADIANT HEATERS



Model #	Description
F170700	HS35LP -Portable Propane Radiant - 35,000 BTU/Hr.

- Heats Up to 875 Sq. Ft.
- No Electricity Required
- Clean Burning, Quiet, Odorless
- Tip-Over Switch, Safety Shut-Off
- P.O.L. Connection with 20' Hose Included
- Operates on Standard 20 Lb. Tank
- Includes Fold-Down Handle
- Fully Assembled, Ready to Use
- Runs Up to 12 Hrs. On a 20 Lb. Tank
- Certified



EFFICIENT RADIANT HEAT

Model #	Description
F170800	HS125LP - Portable Propane Radiant - 125,000 BTU/Hr.
F170850	HS125NG - Portable Natural Gas Radiant - 125,000 BTU/Hr.

- Heats Up to 3,125 Sq. Ft.
- Rugged, Durable Construction
- No Electricity Required
- Welded Frame, Heat Shield, Safety Shut-Off, Regulator
- P.O.L. Connection with 20' Hose Included
- Recommended for Operation On Tanks 100 Lbs. and Larger
- Fully Assembled - Ready to Use
- Includes Handles
- Runs Up to 17 Hrs. On a 100 Lb. Tank
- CSA Certified



SPECIFICATIONS:	HS35LP	HS125LP	HS125NG
Stock Number	F170700	F170800	F170850
Output (BTU/HR)	35,000	125,000	125,000
Heating Area (SQ. FT.)	875	3125	3125
Fuel	Propane	Propane	Natural Gas
Propane Consumption (LBS/HR)	1.6 max	5.8 max	N/A with Natural Gas
Pressure Regulator Settings	22" w.c.	13.5" w.c.	7" w.c.
Flame Safety	Thermocouple Operated Gas Valve	Thermocouple Operated Gas Valve	Thermocouple Operated Gas Valve
Ignition	Piezo	Piezo	Piezo
Power Required	None	None	None
Hose/Regulator	20' with Regulator	20' with Regulator	Regulator Only
P.O.L./Excess Flow Check Valve	Yes	Yes	NA
Shipping Size (L x W x H)	12.4" x 10.24" x 34.25"	16.14" x 16.14" x 35.04"	16.14" x 16.14" x 35.04"
Shipping Weight (LBS)	25	42	42
Shipping Cube	1.85	4.24	4.24

FORCED AIR PROPANE HEATERS

FEATURES:

- 20' LP Gas Hose & Regulator Included

Model #	Description	Heats Up To	Operates Up To
F170035	HS35FA 35,000 BTU/HR	875 Sq. Ft.	12 hrs. on a 20 lb. tank
F170085	HS85FAV 50,000-85,000 BTU/HR	2,125 Sq. Ft.	8 hrs. on a 20 lb. tank
F170125	HS125FAV 75,000-125,000 BTU/HR	3,125 Sq. Ft.	11 hrs. on a 40 lb. tank

LARGE JOBSITES

FEATURES:

- Built-In Thermostat
- 20' LP Gas Hose & Regulator Included



Model #	Description	Heats Up To	Operates Up To
F170170	HS170FAVT 125,000-170,000 BTU/HR	4,250 Sq. Ft.	17 hrs. on a 100 lb. tank
F170180	HS170NG 150,000 BTU/HR	3,750 Sq. Ft.	Natural Gas
F172425	HS400FAVT 250,000-400,000 BTU/HR	10,000 Sq. Ft.	17 hrs. on (2) 100 lb. tanks



HS35FA
F170035

HS125FAV
F170125

HS170FAVT
F170170

HS400FAVT
F172425



CORDLESS FORCED AIR PROPANE



FEATURES:

- Operates 4 Hours On a Single Charge
- Extra Battery (F227964) Extend Run Time to 8 Hrs.

SPECIFICATIONS:

SPECIFICATIONS:		HS60CLP
Stock Number		F128835
BTU/HR Output		30-60,000
Fuel		Propane
Min. Tank Size		20 lbs
Tank Connection		10' hose and reg.
Shipping Size		L 12" x W 21" x H 16"
Weight		22 lbs



Model #	Description	Heats Up To	Operates Up To
F227900	MH35CLP - 35,000 BTU/HR	875 Sq. Ft.	8 hrs on single charge
F128835	HS60CLP 30-60,000 BTU/HR	1,250 Sq. Ft.	4 hrs. on a single charge

FORCED AIR PROPANE HEATERS

SPECIFICATIONS:	HA35FA	HS60FAV	HS85FAV	HS125FAV	HS170FAV	HS400FAVT
Stock Number	F170035	F170060	F170085	F170125	F170170	F172425
Output (BTU/HR)	35,000	30,000-60,000	50,000-85,000	75,000-125,000	125,000-170,000	250,000-400,000
Heating Area (SQ. FT.)	800	1,250	2,000	3,000	4,000	3,500
Output CFM	100	300	300	350	450	1400
Fuel	Propane Gas	Propane Gas	Propane Gas	Propane Gas	Propane Gas	Propane Gas
Min. LP Tank Size	20 lb.	20 lb.	20 lb.	40 lb.	100 lb.	100 lb.
Fuel Consumption (lbs/hr)	1.6	1.2 to 2.08	2.3 to 3.9	3.5 to 5.8	5.8 to 7.8	11.5 to 18.5
Pressure Regulator Settings	10 PSI	28" W.C.	28" W.C.	28" W.C.	28" W.C.	20 PSI
Adjustable Height Control	-	Yes	Yes	Yes	Yes	-
Flame Safety	Yes	Yes	Yes	Yes	Yes	Yes
High Temperature Limit Switch	240 F	240 F	240 F	240 F	240 F	240 F
Ignition	Piezo	Continuous	Continuous	Continuous	Automatic Solid State	Automatic Solid State
Thermostat	-	-	-	-	Built-in	Built-in
Power Required	115 V. 60 Hz 3a	115 V. 60 Hz 3a	115 V. 60 Hz 3a	115 V. 60 Hz 3a	115 V. 60 4a	115 V. 60 4a
Propane Hose-20ft.	1/4" I.D. w/Regulator and POL	3/8" I.D w/Regulator and POL	3/8" I.D. w/Regulator and POL	3/8" I.D. w/Regulator and POL	3/8" I.D. w/Regulator and POL	1/4" I.D. w/Regulator and POL
POL/Excess Flow Check Valve	Yes	Yes	Yes	Yes	Yes	Yes
Shipping Size (L x W x H)	19" x 11.5" x 14"	18.5" x 11.5" x 14"	21" x 11.5" x 16"	20.25" x 12" x 15.5"	26.5" x 11.5" x 16.75"	38.58" x 15" x 22.25"
Net Weight (Includes Hose/Regulator/POL Assembly)	15 lbs.	16lbs.	18 lbs.	23 lbs.	32 lbs.	47 lbs.
Shipping Weight	17 lbs.	20 lbs.	20 lbs.	25 lbs.	34 lbs.	51 lbs.
Shipping Cube	1.8'	1.7'	2.2'	2.7'	3.0'	7.5'

FORCED AIR NATURAL GAS

Stock #	Description	Heats Up To	Operates Up To
F170180	HS170NG 150,000 BTU/HR	3,500 Sq. Ft.	Natural Gas

Model/Stock #	Output (BTU/HR)	Out CFM	Fuel Consumption	Ignition	Power Required	Pressure Regulator Setting
HS170NG/F170180	150,000	450	138 cub. ft./r. (NG)	Automatic Solid State	115 V. 60 4a	4" W.C.

ELECTRIC & VENT FREE HEATERS

Model #	Description
F236120	MH160FAET 1.6 Kw Portable Forced Air Electric Heater
F236125	MH360FAET 3.6 Kw Portable Forced Air Electric Heater

- No Ventilation Required
- Thermostatically Controlled
- Adjustable Heat Angle with Fan Only Option
- Quiet Operation



MH360FAET

Model #	Description
F236130	MH530FAET 5.3 Kw Forced Air Electric Garage Heater
F236135	MH530FAERT 5.3 Kw Forced Air Electric Garage Heater

- No Ventilation Required
- Thermostatically Controlled
- High and Low Heat Settings
- Adjustable Heat Angle with Fan Only Option
- Quiet Operation
- Ceiling Mount with Tilt and Swivel Feature
- Remote Thermostat with F236135 Heater



MH530FAET

VENT FREE PROPANE & NATURAL GAS HEATERS

Model #	Description
F155226	HSVFR10NG - (Natural Gas) - 10,000 BTU/Hr.
F156001	HSSVFR10LPT - (Propane) - 10,000 BTU/Hr. (W/thermostat)
F156040	HSSVFR20NGBT - (Natural Gas) - 20,000 BTU/Hr.
F156050	HSSVFR20LPBT - (Propane) - 20,000 BTU/Hr.
F156081	HSSVFR30NGBT - (Natural Gas) - 30,000 BTU/Hr.
F156091	HSSVFR30LPBT - (Propane) - 30,000 BTU/Hr.

- Radiant Heating System
- Automatic Low Oxygen Shut-Off System (ODS)
- Legs Included
- Wall Mounting Hardware Included
- 4500 Ft. High Altitude Restriction



HSSVFR20LPBT

Model #	Description
F155549	HSVFB10NG - (Natural Gas) - 10,000 BTU/Hr.
F156011	HSSVFB10LPT - (Propane) - 10,000 BTU/Hr. (W/thermostat)
F156020	HSSVFB20NGBT - (Natural Gas) - 20,000 BTU/Hr.
F156031	HSSVFB20LPBT - (Propane) - 20,000 BTU/Hr.
F156060	HSSVFB30NGBT - (Natural Gas) - 30,000 BTU/Hr.
F156071	HSSVFB30LPBT - (Propane) - 30,000 BTU/Hr.

- Blue Flame Burner For Even, Convection Heat
- Automatic Low Oxygen Shut-Off System (ODS)
- Legs Included
- Wall Mounting Hardware Included
- 4500 Ft. High Altitude Restriction



HSSVFB30LPBT

PORTABLE TANK TOP HEATERS

Model #	Description
F242540	MH540 Heater - 48,000 BTU/Hr.

- 540 Degrees of Heat
- 3 Heat Settings: 29,000, 36,000, 48,000 BTU's
- No Electricity Needed
- Instant, Efficient Outdoor Heat
- Quiet, Easy To Use
- No Assembly Required
- Accidental Tip-Over Safety Shut-Off
- Outdoor Use Only

**BURNER HEAD
PIVOTS TO
DIRECT HEAT**

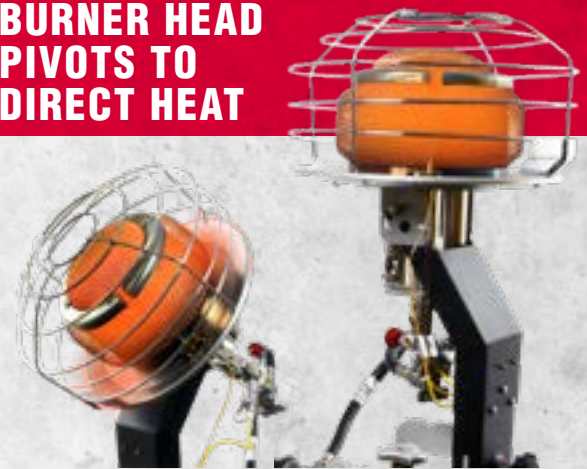

Model #	Description
F242100	MH15T Heater - 10,000-15,000 BTU/Hr.
F242650	MH30T Heater - 10,000-30,000 BTU/Hr.
F242915	MH45T Heater - 10,000-45,000 BTU/Hr.

FEATURES:

- Tip-Over Safety Shut-Offs
- Soft Nose P.O.L.
- Premium Grade Stainless Steel Burning Surface
- Direct Connection to 20 Lb. Bulk Propane Tank
- Operate One or Two Burners at a Time
- Directional, Adjustable Heads
- Polished Chrome Reflector
- Certified
- Outdoor Use Only



PORTABLE PROPANE TORCHES

F272603

- Piezo Ignition
- 36" Handle w/ Molded Arm Support
- 10' Hose
- CSA Certified

MH500DPT
F272603



F272602

- Ergonomic Grip
- 36" Handle
- 10' Hose & Striker
- CSA Certified

MH500LPT
F272602



F272601

- Needle Valve Adjustment
- 31" Total Length
- 10' Hose
- CSA Certified

MH400LPT
F272601



Model #	Description
F272603	MH500DPT Handheld Torch - 500,000 BTU/Hr.
F272602	MH500LPT Handheld Torch - 500,000 BTU/Hr.
F272601	MH400LPT Handheld Torch - 400,000 BTU/Hr.



RADIANT OVERHEAD HEATERS

FEATURES:

- Economical - No electricity required
- Convenient - Easy to Operate & Install
- Maintenance Free - No Moving Parts to Service
- CSA Certified
- Limited 1-Year Warranty - On Gas Control
- Limited 5-Year Warranty - On Burner
- Quiet, Clean, Odor-Free Operation
- Includes Thermostat
- Available in Propane (22,000 BTU/Hr.) or Natural Gas (25,000 BTU/Hr.)



SPECIFICATIONS:	HS22L	HS25N
Stock Number	F125545	F125444
Output (BTU/HR)	22,000	25,000
Heating Area (SQ. FT.)	550	625
Fuel	Propane Gas	Natural Gas
Shipping Size (L x W x H)	29.75 x 12.25 x 7	129.75 x 12.25 x 7
Weight	25 lbs.	25 lbs.
Gas Inlet	.5"	.5"
Manifold Pressure	10"	6"



* Ratings show are for elevations up to 2,000 feet. (In Canada, refer to rating tag.) For elevations above 2,000 feet, ratings should be reduced at the rate of 4% for each 1,000 feet above sea level or as specified by local authority having jurisdiction.

UNIVERSAL ACCESSORIES

Stock #	Description
F200293	Conversion Kit NG to LP
F200294	Conversion Kit LP to NG
09360	PP Thermocouple
F210359	Thermostat



DO NOT use this in sleeping quarters, mobile homes or recreational vehicles.



FEATURES:

- Ships as NG, Includes NG to LP Conversion Kit
- Spark Ignition Features Self-Diagnostic Control Module
- Includes Angle Brackets (2) for Ceiling Mount
- 4" Flue Vent Connection
- Category I Vertical; Category III Horizontal Venting
- CSA Certified



Stock Number	F160550	F160560	F160490
Total Input (BTU/HR)*	50,000	80,000	125,000
Heating Area (SQ. FT)	1,250	2,000	3,125
CFM Output	750	950	1,550
Temperature Rise	45	60	60
Max. Mounting Height (floor to bottom of unit FT)	10	12	12
Net Weight (LBS)	56	79	108
Flue Size*	4"	4"	4"

FUEL CONVERSION KITS

(NG TO LP CONVERSION KITS INCLUDED WITH NEW UNITS, ADDITIONAL KITS SOLD SEPARATELY)

Model #	Description
F260164	Converts 50,000, 80,000 & 125,000 BTU Unit heater from propane to natural gas
F260163	Converts 50,000, 80,000 & 125,000 BTU Unit heater from natural gas to propane

VENT KITS & THERMOSTAT

Model #	Description
F210359	Thermostat

Model #	Description
F102860	Vent Kit - Horizontal - 4"

(Stainless Steel meets Category III venting standards)

Includes: (1) 4" adapter, (1) 45 degree elbow, (1) 4"x12" length, (1) 4" adjustable length (6"-19"), (1) wall thimble, (1) 4" screened termination tee, (1) Hi-temp 2.8 oz. silicone, (1) SS screw kit.

Model #	Description
F102848	Vent Kit - Vertical- 4"

Includes: (1) 4" x 36" B-vent pipe, (2) 4" x 24" vent pipe, (1) 4" 90-degree elbow, wall fire stop, roof flashing, storm collar, vent cap



FAK REPLACEMENT PARTS

Model #	Description
F227416	Nozzle Kit

Replaces part #
27416 & 28710 & 22201

MR. HEATER: MH50KR (09-current)



Model #	Description
F221878	Nozzle Kit

Replaces part #
28741 & 28711

MR. HEATER: MH75KTR (09-current)



Model #	Description
F221879	Nozzle Kit

Replaces part #
28742 & 28712

MR. HEATER: MH125KTR (09-current)
DEWALT: DXH135KT, DXH135HD (13-current)



Model #	Description
F221889	Nozzle Kit

Replaces part #
28743 & 28713

MR. HEATER: MH175KTR (09-current)



Model #	Description
F221891	Nozzle Kit

Replaces part #
22109 & 28714

MR. HEATER: MH210KTR (09-current)
DEWALT: DXH185KT, DXH190HD, DXH215HD(13-current)



Model #	Description
F228795	Spark Plug

Replaces part #21083

MR. HEATER: MH85FAV (2003-08), MH125FAV (2003-CURRENT)
HEATSTAR: HS85FAV (2003-08), HS125FAV (2003-CURRENT)



Model #	Description
F228797	High Limit Switch

Replaces part #21751

MR. HEATER: MH55FAV, MH85FAV
HEATSTAR: HS55FAV, HS85FAV



Model #	Description
F228798	High Limit Switch

Replaces part #22003

MR. HEATER: MH125FAV
HEATSTAR: HS125FAV



Model #	Description
F228796	High Limit Switch

Replaces part #26168

MR. HEATER: MH35FA, MH170FAVT, MH400FAVT
HEATSTAR: HS35FA, HS170FAVT, MH400FAVT



Model #	Description
F221887	Replacement Filter Kit (2009 models through current)

MR. HEATER: MH50KTR, MH75KTR, MH125KTR, MH175KTR, MH210KTR
CONTRACTOR SERIES: TS75KR, TS125KTR, TS175KTR, TS210KTR
CONTRACTOR PLUS: PA50KR, PA75KTR, PA175KTR, PA210KTR
HEATSTAR: HS50KT, HS75KT, HS125KT, HS175KT



Model #	Description
F263016	Replacement Filter Kit (2005 models through 2008)

MR. HEATER: MH50KT, MH75KT, MH125KT, MH175KT, MH210KT
HEATSTAR: HS50KT, HS75KT, HS125KT, HS175KT, HS210KT



Model #	Description
F263015	Replacement Filter Kit

MR. HEATER: MH50KT, MH75KT, MH125KT, MH175KT
HEATSTAR: HS50KT, HS75KT, HS125KT, HS175KT

ALL PRO: SPC-K50, SPC-K100, SPC-K150

UNIVERSAL: K50-FA, K100-FA, K150-FAT

NOTE: For Mr Heater/Heatstar 2003/04 production models



Model #	Description
F221803	Electrode Kit (2005 models and prior)

MR. HEATER: MH50KT, MH75KT, MH125KT, MH175KT
HEATSTAR: HS50KT, HS75KT, HS125KT, HS175KT

Replaces part #21803



Model #	Description
F226831	Rotor Kit (2003 models through current)

MR. HEATER: MH50KT, MH75KT, MH125KT, MH175KT
HEATSTAR: HS50KT, HS75KT, HS125KT, HS175KT

ALL PRO: SPC-, SPC-K50, SPC-K100, SPC-K125, SPC-K150, SPC-K175

UNIVERSAL: K50-FA, K75, K100-FAT, K125, K150-FAT, K175



Model #	Description
F226865	Flame Sensor Kit

MR. HEATER: MH50KR and MH75KTR (2009-current)
 All Mr Heater 2003 - 2008

HEATSTAR: All Models
DeWALT: All Models

Replaces part #s:
 26903
 26924
 26925
 26920



Model #	Description
F221857	Electrode Kit (Kerosene 2006 models through current)

MR. HEATER: MH50KT, MH75KT, MH125KT, MH175KT, MH210KT
MR. HEATER: MH50KR, MH75KTR, MH125KTR, MH175KT, MH210KT
HEATSTAR: HS50KT, HS75KT, HS125KT, HS175KT, HS210KT



Replaces part #21819 and 22144

Model #	Description
F266842	Pump Adjustment Kit (2003 models through current)

MR. HEATER: MH50KT, MH75KT, MH125KT, MH175KT(2003-2008)
MR. HEATER: MH50KR, MH75KTR, MH125KTR, MH175KTR, MH210KTR (2009-present)
HEATSTAR: HS50KT, HS75KT, HS125KT, HS175KT
ALL PRO: SPC-K50, SPC-K100, SPC-K150
UNIVERSAL: K50-FA, K100-FA, K150-FA



HOSES, FITTINGS & REGULATORS

Model #	Description
F271470	15' Propane Appliance Extension Hose Assembly

(3/8" Male Pipe Thread x 3/8" Female Pipe Thread) (3/8" ID High Pressure Hose) Used in addition to the existing propane hose for more length between propane tank and propane appliances.



Model #	Description
F271474	15' Propane Appliance Extension Hose Assembly

(1/4" Male Pipe Thread x 1/4" Female Pipe Thread) (1/4" ID High Pressure Hose) Use as an extension hose for portable propane appliances.



Model #	Description
F271163-(XX)	30 - 60

(3/8" Male Pipe Thread x 3/8" Female Flare) - Most commonly used to hook a low pressure to a propane appliance.



Model #	Description
F273707	5' Propane Hose Assembly
F273707 - 108	9' Propane Hose Assembly

(1/4" Male Pipe Thread x 3/8" Female Flare) Replaces most propane hose assemblies between regulator and fish cooker/smoker, torches, or other propane appliances.



Model #	Description
F273737	2 Tank Hook Up Kit

(30" Hose Assembly with Excess Flow Soft Nose P.O.L.'s on both ends x Full Flow Tee) - Most commonly used to hook multiple bulk tanks to most applications.



Model #	Description
F261210	Thermostat - For portable kerosene (50KR only)

For portable Kerosene (50KR ONLY)



HOSES, FITTINGS & REGULATORS

Model #	Description
F271117	12' RV Quick Connect Hose Assembly
F271138-20	20" Propane hose assembly
F271144-15	15" Propane hose assembly
F271144-24	2' Propane hose assembly
F271144-36	3' Propane hose assembly
F271144-48	4' Propane hose assembly
F271144-60	5' Propane hose assembly
F271144-144	12' Propane hose assembly
F271149-36	3' Propane hose assembly
F271149-48	4' Propane hose assembly
F271149-72	6' Propane hose assembly
F271149-144	12' Propane hose assembly
F271158-12	12" Acme flexible pigtail hose assembly
F271158-15	15" Acme flexible pigtail hose assembly
F271158-18	18" Acme flexible pigtail hose assembly
F271158-24	2' Acme flexible pigtail hose assembly
F271158-36	3' Acme flexible pigtail hose assembly
F271161	22" Replacement propane BBQ hose & regulator assembly with appliance end fitting/acme nut
F271163-30	30" Propane hose assembly
F271163-60	5' Propane hose assembly
F271470	15' Propane appliance extension hose assembly
F271474	15' Propane appliance extension hose assembly
F271802	12' Big/Tough Buddy RV hose
F271803	12' Big/Tough Buddy RV hose with regulator
F271806	12' RV quick connect hose assembly
F273071	5' Propane hose/regulator assembly
F273072	12' Propane hose/regulator assembly
F273076	5' Propane hose/regulator assembly
F273707	5' Propane hose assembly
F273707-108	9' Propane hose assembly
F273710	5' Propane hose assembly
F273711	12' Propane hose assembly
F273716	22" Propane replacement BBQ hose
F273717	5' Propane appliance extension hose assembly
F273720	12' Natural gas patio hose assembly
F276124	5' Propane hose assembly
F276148	5' Propane hose assembly
F271715	Propane "Y" male adapter with handwheel
F271735	Propane "Y" female adapter with handwheel
F271741	30"/15" Propane distribution post/tree
F273655	Excess flow soft nose P.O.L. x 1/4" male pipe thread with handwheel
F273729	1/4" Male pipe thread x 1/4" inverted female flare
F273754	1/4" Male pipe thread x 1"-20 female throwaway cylinder thread
F273755	1/4" Male pipe thread x 1"-20 male throwaway cylinder thread
F273758	Propane bulk cylinder adapter with handwheel

Model #	Description
F273760	90° Elbow
F273762	1/4" Male pipe thread x full flow soft nose P.O.L. with handwheel
F273791	1/4" Male pipe thread x female P.O.L. with acme thread
F276129	9/16" Left hand thread x restricted flow soft nose P.O.L. with handwheel
F276130	9/16" Left hand thread x 1"-20 throwaway cylinder thread with shut-off
F276133	Propane bulk cylinder adapter with appliance end fitting/acme nut
F276139	1/4" Male pipe thread x restricted flow soft nose P.O.L. with handwheel
F276140	Propane male throwaway cylinder adaptor
F276152	1/4" Male pipe thread x 9/16" left hand male thread
F276153	3/8" Male pipe thread x 9/16" left hand male thread
F276154	9/16" Left hand male thread x 9/16" left hand male thread
F276262	3/8" Male pipe thread x 3/8" male flare
F276495	Propane acme nut (black)
F276497	Propane acme nut (green)
F276181	Propane/natural gas connector kit with shut-off valve & excess flow plug
F276186	Propane or natural gas 1/4" quick connector & excess flow male plug
F276187	Propane or natural gas 3/8" quick connector & excess full flow male plug
F276190	Propane or natural gas connector & full flow male plug
F276281	Propane or natural gas full flow male plug
F276328	Propane or natural gas excess flow male plug
F276329	Propane cylinder fill plug
F276330	Propane gas coupling adapter kit
F276334	Propane gas grill "quick connect" adapter
F273719	High pressure regulator with P.O.L. 0-20PSI
F273759	90° Propane low pressure regulator
F273761	90° low pressure regulator with appliance end fitting/acme nut
F273763	Propane two stage vertical regulator
F273766	Propane auto-changeover two stage regulator
F273767	Propane low pressure LP regulator
F273768	Propane grill regulator with acme nut
F273769	Portable propane table top regulator
F273863	Propane two stage horizontal regulator with P.O.L.
F273868	Propane two stage horizontal regulator
F276136	Propane low pressure regulator
F273961	Top 20 (2 each of 20 accessories)
F273967	BBQ (2 each of 21 accessories plus 6 tankfoot)
F273949	Avalon (2 each of 27 accessories)
F273980	Mr. Heater service parts (2 each of 27 items)



ENERCO AIR, WATER & GAS HOSE'S



EW WATER HOSE

Premium product, specially formulated thermoplastic provides a rubber-like look and feel at a fraction of the cost.

TEMPERATURE: +15° F (1.7° C) to +150° F (+65° C)

PRESSURE: 175 psi maximum working pressure

- * Working pressure decreased as temperature increases
- * Weight/foot does not include fittings at each end
- * Custom length available upon request.

Contact Enerco for price & terms quotation.



EWA WATER/AIR HOSE

Rubber-like look and feel enhances flexibility while maintaining durability and cost efficiencies of PVC.

TEMPERATURE: -15° F (-26° C) to +150° F (+65° C) continuous service

PRESSURE: *300 PSI (2.1 Mpa) at 70 F (21 C), 250 PSI (.72 Mpa) at 150 F (+66 C)

- * Weight Per Foot does not include fittings.
- * Strain Relief(s) / Bend Restrictor(s) optional
- * Custom length available upon request.

Contact Enerco for price & terms quotation.