



**COPPUS<sup>®</sup>**  
Portable Ventilators

**CURTISS -  
WRIGHT**

# COPPUS Ventilators

## CONTACT INFORMATION

COPPUS Portable Ventilators  
Curtiss-Wright Steam & Air Solutions  
37 Coats Street, Suite 200  
Wellsville, NY 14895  
Phone: (Int'l +1) 585-593-1234  
Email: PortableVentilator.CW@Siemensgovt.com

## WEB SITE

[www.coppus.com](http://www.coppus.com)

We accept Visa, MasterCard  
and American Express.



## WELCOME

For more than 90 years, COPPUS portable ventilators and cooling products have been recognized as leaders in providing reliable ventilation to meet the demands of safety and maintenance personnel around the world in refineries, chemical plants, steel mills, paper mills, utilities, fabrication shops, and a host of other industries including construction, railroads, airlines, shipbuilding, marine, and food/beverage processing.

## GENERAL APPLICATIONS

- Confined space fresh air supply
- Fume removal (degassing)
- Process cooling
- Equipment cooling
- Source capture fume exhaust
- Personnel heat stress relief
- Air curing and drying of paints and coatings

## FEATURES / ADVANTAGES

- One-year warranty
- Large product selection to meet nearly any portable ventilation or cooling need
- Axial and centrifugal designs
- Choice of drives: electric, pneumatic, steam, or water
- Explosion-proof models
- Premium heavy-duty, continuous-operation motors
- Heavy-duty construction to meet industry demands
- Accommodates flexible duct
- Accessories

## AVAILABLE UPON REQUEST

- Application recommendations
- Product specifications
- Performance curves (pdf)
- Instruction manuals (pdf)



# COPPUS

## Quick reference guide

PRODUCT	MOTOR TYPE	FAN SIZE & TYPE	AIR FLOWS CFM (M <sup>3</sup> /HR)	FEATURES	PAGE
<b>FAQs / Common Terms</b>					<b>4</b>
<b>AIR MAX 12</b>	Electric TE	12 in (305 mm) Vaneaxial	2,200 (3,735)	Lightweight, compact, high air volume	<b>5</b>
<b>CADET</b>	Electric TE or EP	8 in (203 mm) Vaneaxial and Centrifugal	560-1,300 (933-2,209)	Lightweight and compact	<b>6</b>
<b>VANO 175CV, 250CV</b>	Electric TE and EP	8 in (203 mm) 12 in (305 mm) Vaneaxial	1,500-3,000 (2,549-5,098)	Rugged, durable, low-profile design for high air volume	<b>8</b>
<b>DOUBLE-DUTY HEAT KILLER</b>	Electric TE and EP	24 in (610 mm) and 30 in (762 mm) Vaneaxial	7,100-17,000 (12,000-28,890)	Floor mount and optional wall mount	<b>10</b>
<b>JECTAIR JECTAIR HORNET</b>	Compressed Air	8 in (203 mm) to 14 in (356 mm) Venturi	1,370-8,900 (2,328-15,121)	High-air flows, lightweight, maintenance-free	<b>12</b>
<b>TA16-5000 TA16-5500</b>	Electric TE and EP	16 in (406 mm) Tubeaxial	5,000-5,500 (8,495-9,345)	Heavy-duty, high volume for exhaust and fresh air	<b>14</b>
<b>VENTAIR</b>	Electric TE and EP	8 in (203 mm) to 16 in (406 mm) Centrifugal	1,700-10,700 (2,890-18,180)	Five sizes up to 30 HP; supply air to multiple work areas	<b>15</b>
<b>PORTAVENT</b>	Electric TE and EP	5 in (127 mm) & 6 in (152 mm) Centrifugal	560-940 (951-1,597)	Ideal for removing welding fumes; multi-position stand	<b>16</b>
<b>CP-20</b>	Steam or Air	20 in (508 mm) Axial	11,200 (19,029)	Bolts directly to standard API 20 in manway	<b>17</b>
<b>REACTION FANS</b>	Compressed Air	12 in (305 mm) 16 in (406 mm)	2,140-5,100 (3,636-8,665)	Ideal for hazardous locations; all aluminum-cast housing	<b>18</b>
<b>REACTION FANS</b>	Compressed Air	20 in (508 mm) 24 in (610 mm)	11,000-16,900 (18,689-28,700)	Bolts directly to tanks with standard API manways	<b>18</b>
<b>MARINE VENTILATORS</b>	Steam, Air and Water	12 in (305 mm) & 15 in (381 mm) Axial	4,600-8,400 (7,815-14,275)	Cargo tank ventilators; mates to 12.5 in (318 mm) deck opening	<b>20</b>
<b>MARINE VENTURI</b>	Compressed Air	Venturi	3,980-4,870 (6,762-8,274)	Lightweight; mates to 12 in (305 mm) deck opening	<b>21</b>
<b>ACCESSORIES</b>				Add convenience and improve productivity	<b>22</b>

TE = totally enclosed  
EP = explosion proof

# COPPUS

## Frequently asked questions

### COMMON TERMS

#### CONFINED SPACE

Large enough area to be occupied by an individual, but with limited or restricted means for entry or exit; not normally designed for continuous occupancy.

#### CFM

Cubic feet per minute—measurement of flow handled by a fan.

#### STATIC PRESSURE

Usually expressed in inches water gauge (Wg); pressure measured in a direction normal to the air flow; static pressure combined with velocity pressure equals total pressure.

#### BLOCKED TIGHT STATIC PRESSURE

Operating condition in which the fan outlet is completely closed, resulting in no air flow.

#### FREE AIR DELIVERY

Maximum airflow where static pressure across the fan is zero.

#### CAPTURE VELOCITY

Air velocity at any point in front of the hood opening necessary to overcome opposing air currents and to capture the contaminated air at that point.

#### DECIBEL LEVELS

Sound data on COPPUS products are based on tests conducted with units operating at published speeds. No attachments for attenuating sound were used [dBA levels recorded at 5 ft (1.5 m)].

### WHAT TYPE OF VENTILATOR DO YOU RECOMMEND FOR EXPLOSION-PROOF ENVIRONMENTS?

If compressed air is available as your utility, we recommend our RF series ventilators or our Jectair (venturi style) air movers. Pneumatic-drive ventilators are often desirable for hazardous locations. If electric drive is preferred or required, we offer most of our fans and ventilators in explosion-proof models. Explosion-proof units require all electrical connections to be enclosed and moving mechanical pieces to be constructed of material so as not to create sparks. This requires special motors and starters, as well as fan blades and other moving parts to be made of non-sparking materials such as aluminum, stainless steel, fiberglass, or plastic.

### WHY ARE PLUGS NOT STANDARD ON EXPLOSION-PROOF UNITS?

Local electrical codes can vary for hazardous location equipment operation, creating a variety of different plug-receptacle configurations. We recommend that either the plug be installed by a local electrician, or the type and part number of the correct plug be submitted to us in writing for factory installation to ensure local code compliance.

### WHAT IS THE MAXIMUM HORSEPOWER I CAN USE WITH 115V POWER?

A 1.5 HP motor is the largest practical power unit to effectively run on single-phase power. A larger HP motor will generate very large current in-rushes, tripping the electrical protection breaker. Our electrical units have thermal overload protection.

### IS THERE A DIFFERENCE IN AIR VOLUME ON THE SUCTION AND DISCHARGE OF THE VENTILATOR?

No. The given air volume is the same whether the ventilator is used as an exhauster or blower; however, there is a significant difference in the air velocity at a given distance away from the fan. For example: one foot (305 mm) away from the suction end of a 12 in (305 mm) fan, the air velocity will drop by 90 percent compared to only a three percent drop on the supply side.

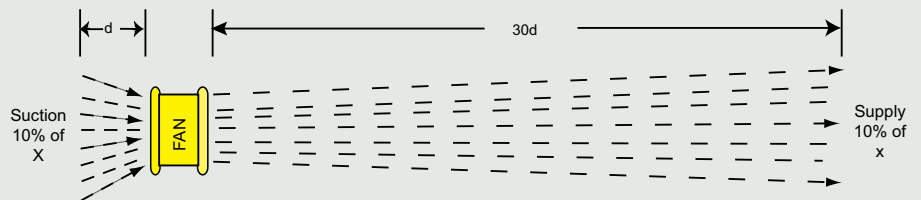

Air velocity is reduced as the distance from the fan increases on both the inlet (exhaust) and outlet (delivery) sides; however, the rate of reduction in air velocity is significantly greater on the inlet side of the fan.

$d$  = diameter of the fan face  
 $x$  = air velocity of the fan face



# COPPUS Air MAX-12

Economical, high-volume tube axial blower

## MODEL/SPECIFICATIONS

### MOTOR

TE 3/4 HP with integral on/off switch, 115V/6.8 amp, Class B insulation, auto reset thermal overload protection; GFCI at plug end on 115V models.

### FREE AIR

2,200 cfm (3,740 m<sup>3</sup>/hr)

### WEIGHT

44 lbs (18.14 kg)

### HOUSING

18-gauge steel, powder-coated with carry handle and anti-vibration foot pads; rolled bead on ends for added strength and attaching flexible ducting; safety screens attached per OSHA guidelines.

#### PLEASE NOTE:

Not available for Class 1, Div. 1 (hazardous locations) applications.

## DESCRIPTION

This 12 in (305 mm), lightweight, rugged blower delivers up to 2,200 cfm (3,740 m<sup>3</sup>/hr) for confined space ventilation and fresh air supply.

## FEATURES / ADVANTAGES

- Rugged, all-steel housing construction
- Integral on/off motor switch
- Fixed guide vanes for improved performance
- Glass-reinforced, polypropylene, non-sparking fan blade
- 20 ft (6.1 m) cord with GFCI at plug end
- Anti-vibration foot pads
- Available with TE motors only; not for use in hazardous areas



## DIMENSIONS

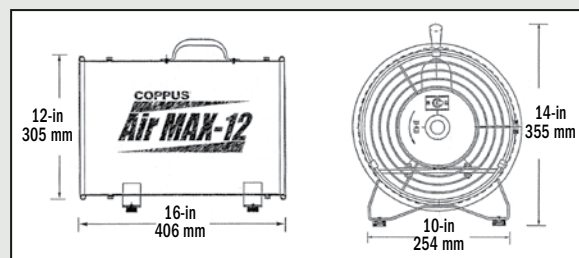

## TECHNICAL DATA

FREE AIR DECIBEL LEVELS	
Air MAX 12	74 dBA

MODEL	AIR FLOW THROUGH DUCT (STRAIGHT RUNS)							
	FREE AIR		10 ft 3.05 m		20 ft 6.10 m		30 ft 9.15 m	
	cfm	m <sup>3</sup> /hr	cfm	m <sup>3</sup> /hr	cfm	m <sup>3</sup> /hr	cfm	m <sup>3</sup> /hr
Air MAX	2,200	3,740	2,120	3,602	2,025	3,440	1,890	3,211



Model VAC

# COPPUS CADET® Vaneaxial

Ideal for utility underground and light industrial confined space ventilation

## MODEL/SPECIFICATIONS

### MODEL VEP

Vaneaxial hazardous location electric drive.



## DESCRIPTION

These versatile, rugged and economical ventilators deliver exceptional air flow in a compact, lightweight design—and their non-corrosive injection-molded housing is nearly indestructible. They are ideal for utility underground and light manufacturing confined space ventilation and are available in a variety of models.

## FEATURES / ADVANTAGES

- Flame-resistant injection-molded housing
- Glass-filled, polyester resin, spark-resistant fan blade
- Accommodates 8 in (203 mm) flexible duct
- 60Hz/50Hz AC motors
- Hazardous location motors NEC Class/Div1

## DIMENSIONS

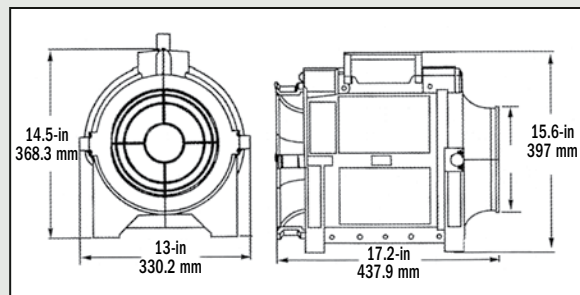

# TECHNICAL DATA

VANEAXIAL MODELS							
MODEL	DRIVE	MOTOR	HP	WEIGHT		FREE AIR	
				lbs	kg	cfm	m <sup>3</sup> /hr
VAC1	Electric 115V/60Hz	TE	1/2	35	16	867	1465
VAC2	Electric 110V/50Hz	TE	1/2	35	16	804	1358
VAC3	Electric 230V/60Hz	TE	1/2	35	16	867	1465
VAC4	Electric 220V/50Hz	TE	1/2	35	16	804	1358
VEP1	Electric 115V/60Hz	EP	1/2	40	19	867	1465
VEP2	Electric 110V/50Hz	EP	1/2	40	19	804	1358
VEP3	Electric 230V/60Hz	EP	1/2	40	19	867	1465
VEP4	Electric 220V/50Hz	EP	1/2	40	19	804	1358

PERFORMANCE THROUGH 90-DEGREE BEND(S)					
1-90-degree		2-90-degree		3-90-degree	
cfm	m <sup>3</sup> /hr	cfm	m <sup>3</sup> /hr	cfm	m <sup>3</sup> /hr
776	1,318	766	1,301	756	1,284
730	1,240	720	1,223	710	1,206
776	1,318	776	1,301	756	1,465
730	1,240	720	1,223	710	1,206
730	1,240	659	1,119	602	1,023
776	1,318	766	1,301	756	1,284
730	1,240	720	1,223	710	1,206
776	1,318	766	1,301	756	1,284
730	1,240	720	1,223	710	1,206

FREE AIR DECIBEL LEVELS	
VAC1	88 dBA



# COPPUS VANO® 175CV & 250CV

Rugged, reliable ventilator models



## MODEL/SPECIFICATIONS

### MODEL 175CV

3/4 HP  
1,500 cfm (2,549 m3/hr)

### MODEL 250CV

1 HP  
3,000 cfm (5,098 m3/hr)

### HAZARDOUS LOCATION MODELS

VANO models are available with hazardous location (EP\*) motors that meet NEC Class I, Division I, Group D and Class II, Division I, Groups E, F, G specifications.

*\*EP models do not include plugs*

## DESCRIPTION

COPPUS ventilators revolutionized air moving equipment more than 60 years ago with the introduction of the VANO models. The VANO models offer a fixed guide vane design that delivers high volumes of air while maintaining static pressure for exhausting fumes and delivering fresh air. A rugged, durable, high-performance design makes the VANO models ideal for ventilating tanks, process vessels, tank cars, manholes and other confined spaces.

## FEATURES / ADVANTAGES

- Straightening fixed guide vanes for improved static pressure performance
- Accepts ducting at inlet and outlet ends
- Converts to exhaust fumes from bottom of tanks
- Available with totally enclosed (TE) or explosion-proof (EP) motors and compatible switch; all models supplied with 15 ft (4.572 m) power cord
- Heavy-gauge, powder-coated steel and cast aluminum construction
- Spark-resistant fan blades
- Automatic thermal overload protection standard on VANO 175CV and 250CV models
- Optional tripod and transport cart.

## DIMENSIONS

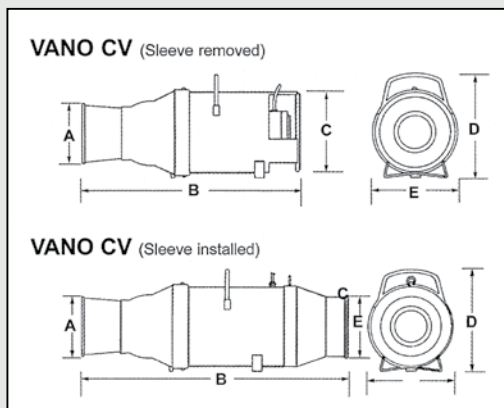

MODEL	in/mm					WT lbs/kgs	Duct inch/mm
	A	B	C	D	E		
<b>175CV</b> Sleeve removed	8.38 213	31.88 810	10.62 270	13.75 349	11.38 289	62 28	8 203
<b>175CV</b> Sleeve installed	8.38 213	38.88 988	8.38 213	13.75 349	11.38 289	73 33	8 203
<b>250CV</b> Sleeve removed	12 305	33 838	12.25 311	15.62 397	13.25 337	86 39	12 305
<b>250CV</b> Sleeve installed	12 305	36 914	12 305	15.62 397	13.25 337	93 41	12 305



## TECHNICAL DATA

FREE AIR DECIBEL LEVELS	
VANO 175CV	90 dBA
VANO 250CV	92 dBA

AIR FLOW THROUGH FLEXIBLE DUCT (STRAIGHT RUNS)								
MODEL	10 ft 3.05 m		20 ft 6.10 m		30 ft 9.15 m		50 ft 15.25 m	
	cfm	m <sup>3</sup> /hr	cfm	m <sup>3</sup> /hr	cfm	m <sup>3</sup> /hr	cfm	m <sup>3</sup> /hr
175CV	1,400	2,379	1,300	2,209	1,200	2,039	1,080	1,835
250CV	2,940	5,098	2,620	4,452	2,480	4,214	2,300	3,908

Performance schedule represents 60 Hz synchronous speeds; 50 Hz models perform at approximately 80 percent of listed schedules.

### CONVERTIBLE DESIGN

By simply removing the inlet sleeves, the VANO 175CV and 250CV convert to vertical exhaust units.



### WITH INLET SLEEVE INSTALLED

The flexible duct can be attached to inlet and outlet ends. This allows fumes to be exhausted from a confined space, or fresh air to be delivered from a remote area.

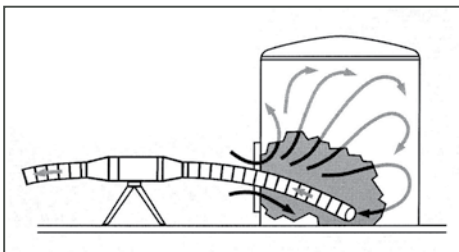

### WITH INLET SLEEVE REMOVED

Cut-outs on inlet end of CV models are exposed for exhausting heavier-than-air fumes from the bottoms of tanks, vats, drums, and other confined spaces.

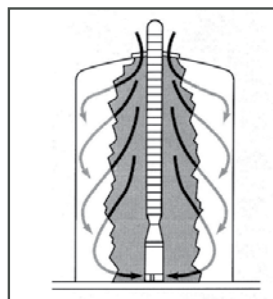

## OPTIONAL ACCESSORIES

### TRIPOD

Lifts VANO 175 and 250 models off ground to prevent dirt pick-up and allow smooth duct flow into elevated confined space openings. Bolts to VANO and allows positioning from 45 degrees up to 45 degrees down. Legs fold for storage. Also accepts Jectair models.



### TRANSPORT CART

Built of tubular steel with large diameter rubber tires increases portability of VANO 175 and 250 models. Duct can be attached without removing VANO from cart. Built-in crane lift hook.



# COPPUS DOUBLE-DUTY™ HEAT KILLER

Powerful industrial fan for cooling products processes and personnel



## MODEL/SPECIFICATIONS

### ADJUSTABLE GUIDE VANES

Adjustable guide vanes create a number of airflow patterns from gentle breeze to jet blast. Most efficient air flow can be determined by positioning guide vanes during operation.

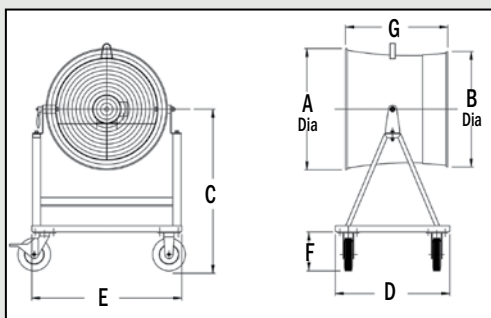

## DESCRIPTION

With airflows up to 17,000 cfm (28,890 m<sup>3</sup>/hr) the Double-Duty™ Heat Killer (DDHK) is one of the most powerful and versatile portable air movers on the market today. The patented, adjustable guide vane design allows air flow control—from a gentle breeze for personnel cooling, to a concentrated jet blast for product and process cooling.

## FEATURES / ADVANTAGES

- Adjustable guide vanes allow varied air movement from a gentle breeze to a jet blast
- Available in 24 in (610 mm) and 30 in (762 mm) models
- Available in floor stand or wall mount models
- Heavy-duty, rugged steel housing and frame
- Protective screens meet OSHA guidelines
- Available with TE and EP motors
- Hazardous location switches and motors meet NEC Class I, Division I, Group D and Class II, Division I, Groups F and G specifications
- Thermal overload protection on motors

*\*Note: EP plugs sold separately to meet local codes*

## DIMENSIONS

FLOOR STAND DIMENSIONS								
FAN SIZE	in/mm							NET WT lbs/kgs
	A	B	C	D	E	F	G	
<b>24 in</b> <b>610 mm</b>	29.6 752	28.3 719	39.5 1,003	28.0 711	36.5 927	9.5 241	25.0 635	250 113
<b>30 in</b> <b>762 mm</b>	36.8 935	33.4 848	39.5 1,003	28.0 711	36.5 927	9.5 241	28.0 711	340 154

## TECHNICAL DATA

AIR VELOCITIES FPM (M/MIN) AT VARIOUS DISTANCES FROM FAN									
MODEL	10 ft 3 m		30 ft 9 m		50 ft 15 m		70 ft 21 m		90 ft 27 m
	JB	DF	JB	DF	JB	DF	JB	DF	JB
24K10D	1,675 508	670 203	840 255	375 114	560 170	280 85	350 106	230 70	185 56
30K30D	2,250 686	1,280 390	1,000 304	520 159	900 274	340 104	700 213	310 95	475 145

JB = jet blast  
DF = diffused flow

FREE AIR DECIBEL LEVELS	
24K07D	79 dBA
24K10D	85 dBA
30K30D	92 dBA

PERFORMANCE SPECIFICATIONS						
MODEL	FAN SIZE		MOTOR		AIR VOLUME	
	in	mm	HP	rpm	cfm	m <sup>3</sup> /hr
24K07D	24	610	3/4	1,750	7,100	12,060
24K10D	24	610	1	1,750	9,500	16,140
30K30D	30	610	3	1,750	17,000	28,890

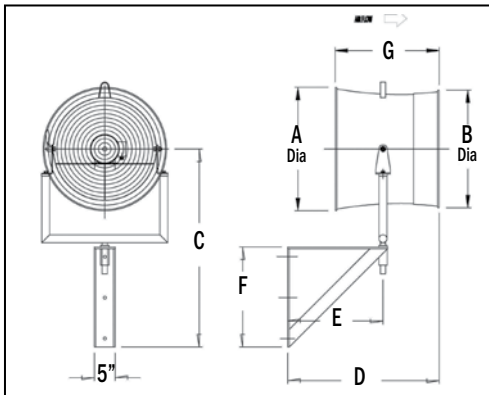

WALL MOUNT DIMENSIONS							
FAN SIZE	in/mm						
	A	B	C	D	E	F	G
24 in 610 mm	29.6 752	28.3 719	47.6 1208	36.4 925	22.9 582	24.0 610	25.0 635
30 in 762 mm	36.8 935	33.4 848	52.7 1338	39.6 1006	25.1 638	26.1 664	28.0 711

### DDHK WALL MOUNT KIT

Easy retrofit wall mount kits are available for existing floor stand models; kits include wall bracket and fan U-bracket.

- Frees up valuable floor space
- Ensures permanent location
- Design permits 360 degree rotation with variable tilt up or down of 155 degrees (90 degrees down, 65 degrees up)



# COPPUS Jectair® HP and Hornet HP

High-performance, highly efficient  
Venturi air movers

## MODEL/SPECIFICATIONS

### OPERATING PRINCIPLE

Compressed air or steam\* is admitted into the Jectair through a single inlet connection in the housing leading to the mixing chamber. The air or steam jetted from the nozzle creates a “Venturi” action that induces a large volume of surrounding air to enter the Jectair through the aerodynamic inlet bell. The air is then discharged at high velocity through the horn-shaped diffuser.

\* **Steam use on steel diffuser units only.**

**NOTE: Operating efficiency depends on compressed air volume and pressure (see efficiency performance charts on next page).**

### SAFETY PRECAUTIONS

- Use bonding cables (standard on all COPPUS Jectair air movers) when operating in hazardous locations to prevent static electricity discharges
- Secure unit before admitting compressed air (or steam) to prevent damage or injury from high-reaction force
- Do not allow solid objects or debris to enter inlet housing during operation
- When exhausting fumes from an enclosed vessel, take care not to create a vacuum that could collapse the vessel

### JECTAIR DESCRIPTION

The unmatched performance of the COPPUS Jectair® HP is recognized throughout the industry. When compared with older-style air horns, the patented air mixing chamber of the Jectair® HP can produce up to a 40:1 air flow conversion and up to 26 percent savings on compressed air consumption.

### FEATURES / ADVANTAGES

- Available in five sizes: 3S-HP, 3-HP, 6-HP, 8-HP, or 9-HP
- High-performance (HP) and Hornet models available in three sizes: 3S-HP, 3-HP and 6-HP
- Air flows range from 1,370 to 8,900 cfm (2,328 to 15,121 m<sup>3</sup>/hr)
- Induction ratios up to 40:1
- Multiple expansion nozzles machined into housing
- High static pressure capabilities
- Diffuser material available in steel, aluminum or shock-resistant polymer (Hornet HP)
- No moving parts (virtually maintenance-free)
- Static bonding cable (standard on all models) with spring tension grip and replaceable contact tips.

### OPTIONS

- Accepts flexible duct on diffuser end
- Inlet duct adapter available
- Tripod for stationary mounting available

### JECTAIR HORNET DESCRIPTION

The Jectair Hornet HP features a lightweight, shock-resistant, conductive polymer diffuser that is virtually indestructible

### JECTAIR HORNET FEATURES / ADVANTAGES

- Available in three sizes: 3S-HP, 3-HP and 6-HP
- Polymer safely dissipates static electricity charges
- Diffuser is constructed of linear low-density polyethylene, rated
- UL 94 with maximum operating temperature of 160° Fahrenheit (93° Celsius)

# TECHNICAL DATA

EFFICIENCY PERFORMANCE AT SELECT INLET PRESSURES INDUCTION RATIO = cfm of total airflow/cfm of compressed air								
INLET PRESSURE	MODEL	AIR FLOW		AIR CONSUMPTION		INDUCTION RATIO	BLOCK TIGHT STATIC PRESSURE	
		cfm	m <sup>3</sup> /hr	cfm	m <sup>3</sup> /hr		inch	mm
60 psig 4,2 kg/cm <sup>2</sup>	3S-HP	1,370	2,328	47	80	29.1	5.8	147
	3-HP	1,520	2,595	47	80	32.3	5.8	147
	6-HP	3,980	6,762	98	167	40.6	4.3	109
	8	5,600	9,515	178	302	31.5	3.9	99
	9	6,880	11,096	265	450	25.8	5.5	140
80 psig 5,6 kg/cm <sup>2</sup>	3S-HP	1,530	2,600	61	104	25.1	7.5	191
	3-HP	1,700	2,888	61	104	27.8	7.5	191
	6-HP	4,500	7,645	126	214	35.7	5.6	132
	8	6,250	10,620	233	396	26.8	5.2	132
	9	8,000	13,592	366	571	23.8	6.8	173
100 psig 7 kg/cm <sup>2</sup>	3S-HP	1,660	2,820	72	122	23.0	8.9	224
	3-HP	1,860	3,160	72	122	25.8	8.9	224
	6-HP	4,870	8,274	153	260	31.8	6.7	170
	8	6,750	11,469	282	479	23.9	6.2	157
	9	8,900	15,121	410	697	21.7	7.7	196

VENTURI		
ITEM	PSIG	dba
Jectair 3	80	88
Jectair 3	60	85
Jectair 3	40	81
Jectair 6	80	92
Jectair 6	60	89
Jectair 6	40	85
Jectair 8	80	94
Jectair 8	60	91
Jectair 8	40	87
Jectair 9	80	95
Jectair 9	60	92
Jectair 9	40	88

Maximum operating pressure 150 psig (10.5 kg/cm<sup>2</sup>)

PERFORMANCE THROUGH VARIOUS LENGTHS OF FLEXIBLE DUCT AT 80 PSIG (7 KG/CM <sup>2</sup> ) High static pressure capabilities of the JectairHP air mover permit use of long runs of flexible duct on outlet or inlet diffuser.						
MODEL	DUCT Diameter	FREE AIR	20 ft/6 m	30 ft/9 m	40 ft/12 m	50 ft/15 m
	in/mm	cfm/m <sup>3</sup> /hr	cfm/m <sup>3</sup> /hr	cfm/m <sup>3</sup> /hr	cfm/m <sup>3</sup> /hr	cfm/m <sup>3</sup> /hr
3-HP	8/203	1,700/2,888	1,550/2,634	1,480/2,515	1,410/2,396	1,350/2,294
6-HP	12/305	4,500/7,645	4,020/6,830	3,860/6,558	3,715/6,312	3,580/6,083
8	14/356	6,250/10,620	5,550/9,431	5,280/8,972	5,050/8,581	4,850/8,241
9	14/356	8,000/13,592	6,850/11,640	6,550/11,130	6,250/10,620	6,000/10,195

DIMENSIONS								
MODEL	in/mm							WT lbs/kgs
	A	B	C	D	MOUNTING SLOTS			
					E	No.	Width	
3S-HP	6.0 152	16.5 419	7.5 190	0.5 13	6.5 165	3	0.4 10	6 2.7
3-HP	7.3 185	33.0 838	7.5 190	0.5 13	6.5 165	3	0.4 10	9 4.1
6-HP	12.0 305	44.2 1,123	11.5 292	1 25	10.8 274	3	0.4 10	21 9.5
8	14.0 356	46.0 1,168	14.3 363	1 25	13.5 345	3	0.5 13	35 15.9
9	14.0 356	46.0 1,168	16.8 427	1 25	15.3 387	10	0.9 23	42 19.0

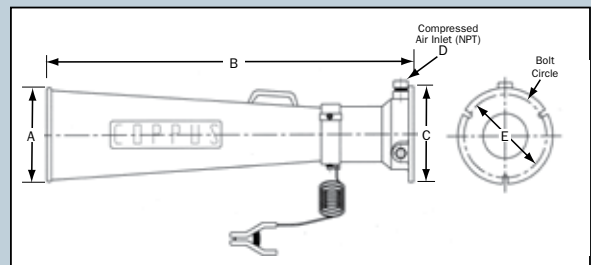



# COPPUS TA16

Delivers large volume with high-static pressure capabilities

## MODEL/SPECIFICATIONS

### MODEL TA16-5500

2-HP, 5,500 cfm (9,345 m<sup>3</sup>/hr) free air

### MODEL TA16-5000

1 1/2-HP, 5,000 cfm (8,495 m<sup>3</sup>/hr) free air



TA16 with optional caster kit

## DESCRIPTION

The unique fan blade design not only allows exceptionally high air volume but also maximizes static pressure for better performance through longer runs of air duct. Typical ventilation applications include large tanks, tunnels, towers, and shipboard compartments; this fan is also ideal for product and process cooling.

## FEATURES / ADVANTAGES

- TE or EP motor
- Thermal overload protection
- Powder-coated, heavy-gauge steel housing
- Cast-aluminum or glass-filled fan blade provides spark-resistance
- Skid-mounted for stability (optional casters available)
- Duct can be connected at inlet and outlet ends
- Optional caster kit available

## DIMENSIONS

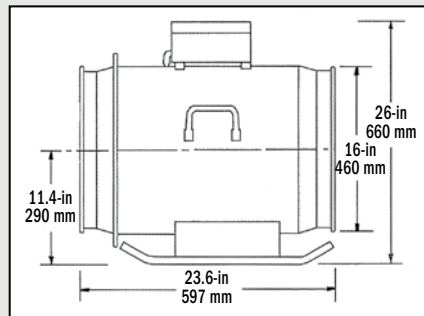

## TECHNICAL DATA

FREE AIR DECIBEL LEVELS	
TA16	96 dBA

MODEL	AIR FLOW THROUGH FLEXIBLE-DUCT (STRAIGHT RUNS)					
	10 ft 3.05 m		50 ft 15.25 m		100 ft 30.5 m	
	cfm	m <sup>3</sup> /hr	cfm	m <sup>3</sup> /hr	cfm	m <sup>3</sup> /hr
TA16-5500 - 2HP	5,320	9,039	4,775	8,113	4,250	7,721
TA16-5000 - 1 1/2HP	4,835	8,215	4,340	7,379	3,875	6,585





# COPPUS Ventair<sup>®</sup> TM

High-pressure centrifugal blower/exhauster

## MODEL/SPECIFICATIONS

### ELECTRICAL SPECIFICATIONS

- Ventair models available with TE or EP (NEC classification) motors
- Single-phase (TM-4 only) specifications
- Multiple motor electrical classification

### OPTIONS AND ACCESSORIES

- Motor starters
- Beaded or flanged diffusers
- Flexible duct
- Multiple inlet duct adapter
- Vibration isolators

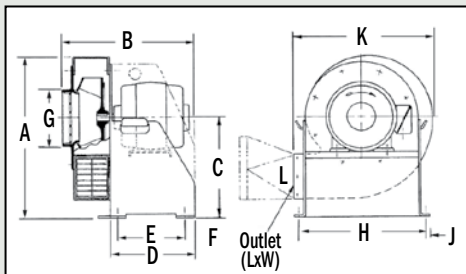

## DESCRIPTION

This is a rugged, high-volume, high-pressure centrifugal fan. Backwardly inclined fan blades yield stable air flow through small diameter or long runs of duct. The high static pressure capabilities make this an ideal air mover for supplying fresh air or source-capturing welding and other fumes for multiple remote locations with optional, multiple inlet adapter.

**NOTE: TM-5, TM-6, & TM-9 special order only.**

## FEATURES / ADVANTAGES

- Available in 1-, 2-, 5-, 15-, and 30-HP motors producing up to 10,700 cfm (18,179 m<sup>3</sup>/hr)
- One-piece, cast aluminum, spark-resistant, abrasion-resistant, dynamically balanced fan wheel
- Heavy-gauge steel housing and base protects fan and motor
- Backward curved airfoil-shaped blades provide non-overloading power characteristics allowing peak performance through long runs of duct
- TE and EP motors available
- 3,500 rpm motor directly connected to the fan wheel
- Variable outlet configuration



Optional four-inch (101.6 mm), multiple-duct adapter

## DIMENSIONS

MODEL	in/mm										L (OUTLET) in/mm	WT lbs/kgs
	A	B	C	D	E	F	G	H	J	K		
TM-4	22.5 572	18.8 478	14.0 356	12.0 305	8.0 203	2.0 51	8.0 203	16.5 419	1.0 25	19.0 483	7.4 X 5.5 188 X 10	110 50
TM-5	26.2 665	23.6 599	16.5 419	15.0 381	11.7 298	1.5 38	10.0 254	19.5 495	1.0 25	22.0 559	8.7 X 6.6 221 X 168	130 59
TM-6	28.8 732	24.9 632	17.5 445	15.5 394	12.2 311	1.5 38	12.0 305	22.5 572	1.0 25	25.2 651	9.6 X 7.4 244 X 234	205 93
TM-8	35.6 904	32.6 828	22.0 559	21.0 533	16.0 406	2.0 51	14.0 356	28.8 734	1.5 38	30.0 762	11.5 X 9.2 292 X 234	550 250
TM-9	42.0 1,067	38.5 978	26.0 660	27.0 686	22.7 578	2.0 51	16.0 406	31.5 800	1.5 38	34.2 870	11.5 X 9.2 292 X 234	670 304

## TECHNICAL DATA

FREE AIR DECIBEL LEVELS	
TM-4	84 dBA
TM-5	88 dBA
TM-6	94 dBA
TM-8	100 dBA

AIR DELIVERY AT 3,500 RPM							
MODEL	HP	FREE AIR		NOMINAL DUCT SIZE		STATIC PRESSURE to 24 inch WG max	
		cfm	m <sup>3</sup> /hr	in	mm	in	mm
TM-4	1	1,700	2,887	8	203	6.0	152
TM-5	2	2,500	4,248	10	254	8.2	208
TM-6	5	4,100	6,966	12	305	12.7	323
TM-8	15	7,450	12,658	14	356	18.6	472
TM-9	30	10,700	18,179	16	406	24.2	615





# COPPUS Portavent®

Versatile centrifugal ventilator for  
source capture fume exhaust

## MODEL/SPECIFICATIONS

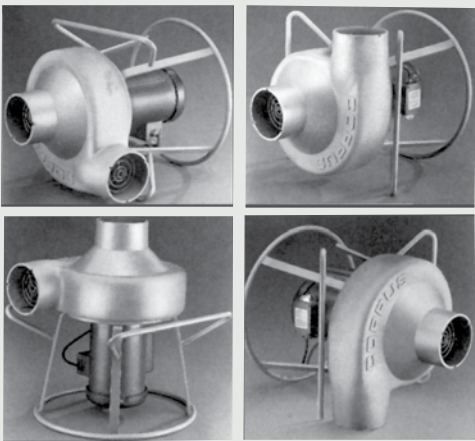

Unique stand design offers multiple set-up options.

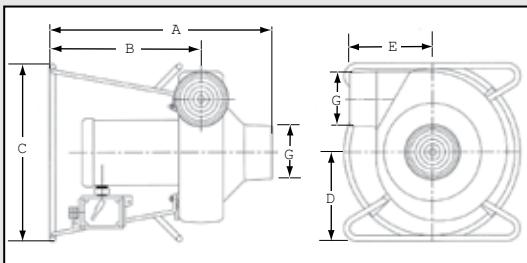

## TECHNICAL DATA

FREE AIR DECIBEL LEVELS	
PV-500	84 dBA
PV-750	87 dBA
PV-1000	90 dBA

MODEL	WT lbs/kgs		FREE AIR DELIVERY cfm/m <sup>3</sup> /hr	NOMINAL DUCT SIZE in/mm	STATIC PRES- SURE BLOCK TIGHT (in H <sub>2</sub> O)
	TE	EP			
PV-500	57	60	560	5	5.3
	26	27	952	127	
PV-750	69	72	815	6	8.5
	31	32	1,385	152	
PV-1000	70	73	940	6	7.0
	32	33	1,597	152	

## DESCRIPTION

The design, performance and versatility of the PORTAVENT centrifugal ventilator make it ideal for a wide range of industrial applications—welding and other fume removal; small tank purging; equipment cooling; confined space ventilation; and other maintenance and safety applications.

**NOTE: PV-500 & PV-750 special order only.**

## FEATURES / ADVANTAGES

- Available in three models offering 560 to 940 cfm (951 to 1,597 m<sup>3</sup>/hr)
- Direct-drive 3,500 RPM fan motor
- Cast aluminum fan and housing provide spark-resistant construction
- Unique, multi-position stand offers a variety of convenient set-ups
- Accepts flexible duct at inlet and outlet ends
- Backwardly inclined airfoil blades prevent motor overloads
- Inlet and outlet screens meet OSHA standards
- TE and EP motors available on all models



## DIMENSIONS

MODEL	in/mm						
	A	B	C	D	E	F	G
PV-500	22.4	14.8	19.0	9.5	8.4	5.4	4.9
	569	376	483	241	213	137	124
PV-750	22.9	15.6	19.0	9.5	9.3	5.9	5.9
	582	396	483	241	236	150	150
PV-1000	22.9	15.6	19.0	9.5	9.3	5.9	5.9
	582	396	483	241	236	150	150





# COPPUS CP-20

Air- or steam turbine-driven blower/exhauster

## MODEL/SPECIFICATIONS

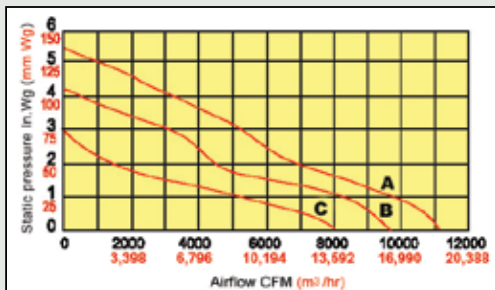

- A = 80 psig (5, 6 kg/cm<sup>2</sup>) at large nozzle or 150 psig (10,6 kg/cm<sup>2</sup>) at small
- B = 60 psig (4, 2 kg/cm<sup>2</sup>) at large nozzle or 115 psig (8, 1 kg/cm<sup>2</sup>) at small
- C = 40 psig (2, 8 kg/cm<sup>2</sup>) at large nozzle or 80 psig (5, 6 kg/cm<sup>2</sup>) at small

## DESCRIPTION

This powerful fan is designed for fast and thorough degassing, ventilating or cooling of large process vessels such as columns, towers, reactors, scrubbers, furnaces, and storage tanks.

## FEATURES / ADVANTAGES

- Delivers air flow up to 11,200 cfm (19,029 m<sup>3</sup>/hr)
- Can be used as blower or exhauster
- Fits 20 in (508 mm) API tank opening
- Cast aluminum housing and fan blade
- Stainless steel turbine buckets
- Separate stainless steel nozzles for high- or low-pressure operation
- Fan assembly shaft rotates on permanently sealed ball bearings
- Stationery expansion nozzles

## DIMENSIONS

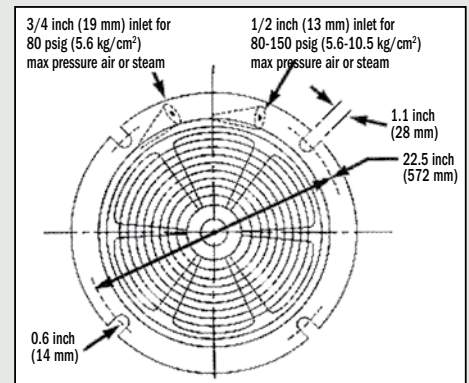
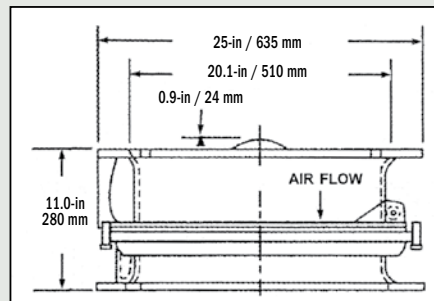

## TECHNICAL DATA

AIR AND STEAM DRIVEN		
CP-20	80 psig	108 dBA
CP-20	60 psig	107 dBA
CP-20	40 psig	105 dBA

High-pressure inlet equals small nozzle

- 1/2 in NPT connection

Low-pressure inlet equals large nozzle

- 3/4 in NPT connection

STEAM AND AIR CONSUMPTION				
STEAM/AIR PRESSURE psig kg/cm <sup>2</sup>	STEAM CONSUMPTION lbs/hr / kg/hr		AIR CONSUMPTION scfm / m <sup>3</sup> /hr	
	SMALL NOZZLE	LARGE NOZZLE	SMALL NOZZLE	LARGE NOZZLE
150 / 10.6	640 / 209		220 / 178	
115 / 8.1	510 / 231		178 / 302	
80 / 5.6	380 / 172	740 / 336	128 / 217	250 / 425
60 / 4.2		590 / 268		194 / 330
40 / 2.8		440 / 200		142 / 241

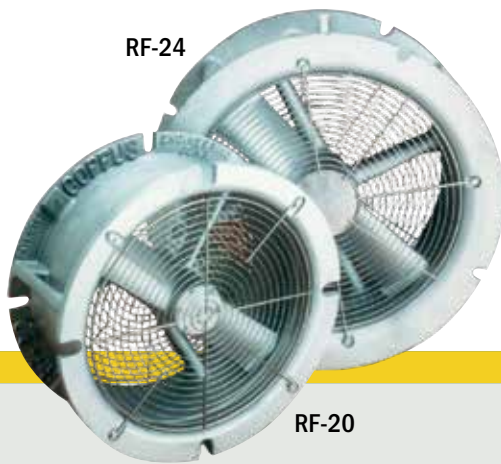

RF-24

# COPPUS Reaction Fans

## RF-12, RF-16, RF-20, RF-24

Air-driven reaction fans

### MODEL/SPECIFICATIONS



RF-12

RF-16

### DESCRIPTION

Rugged, cast aluminum housing and fan blade make these fans ideal for hazardous locations and demanding ventilation projects. The RF design uses action-reaction principles; compressed air is discharged through nozzles located at the tip of the fan blade providing extremely efficient, high-volume, low-maintenance air movers.

### RF-20, RF-24 FEATURES / ADVANTAGES

- 11,000 to 16,900 cfm (18,689 to 28,713 m<sup>3</sup>/hr) at 80 psig\*
- Use for fresh air supply or fume exhaust
- Can be carried or rolled to job site
- Spark-resistant cast aluminum housing and fan blade
- Permanently lubricated bearings
- Flanges mate with 20 in (508 mm) and 24 in (610 mm) API tank openings

### RF-12, RF-16 FEATURES / ADVANTAGES

- 2,100 to 5,100 cfm (3,566 to 8,665 m<sup>3</sup>/hr) at 80 psig
- Use for fresh air supply or fume exhaust
- Low compressed air consumption
- Spark-resistant, cast-aluminum housing and fan blade
- Virtually maintenance free
- Permanently lubricated bearings eliminate line oiler
- Cast-in handles and feet
- Cast-in bead to accept 12 in (305 mm) and 16 in duct (406 mm)
- Bolt holes allow optional adapter plates attachment

### SWING-OUT ASSEMBLY FOR RF-20/24 AND CP-20

Personnel and equipment egress or entrance to tanks and vessels can be achieved quicker, easier and safer with the RF-20/24 and CP-20 swing-out models; mounts to standard API 20 in (508 mm) or 24 in (610 mm) tank openings. Swing-out gate (constructed of cast aluminum) is held in closed position with industrial strength hook and loop fastener that can be opened and closed easily by pulling or pushing



\*Maximum operating pressure 100 psig (7 kg/cm<sup>2</sup>)

RF-20 PERFORMANCE

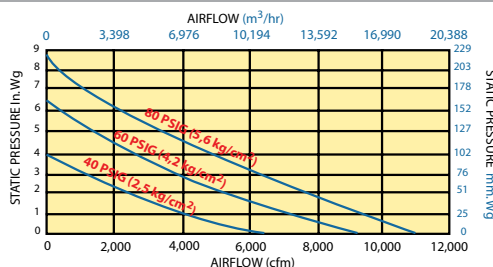

RF-24 PERFORMANCE

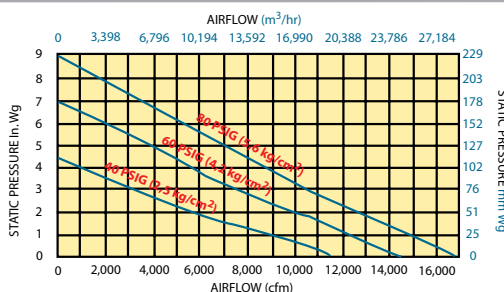

# TECHNICAL DATA

RF-12, RF-16 DIMENSIONS								
MODEL	in/mm							WT lbs/kgs
	A	B	C	D	E	F	G	
RF-12	14.5 368	6.4 163	12.0 305	10.5 267	10.9 276	11.8 299	10.8 273	39 18
RF-16	16.4 416	8.4 213	17.4 442	14.5 368	15.4 391	15.8 401	12.0 305	50 23

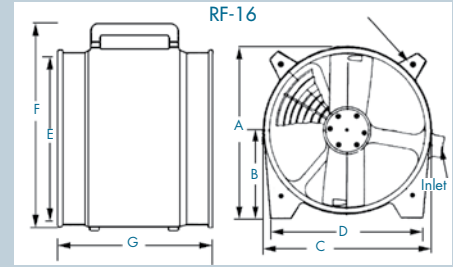

RF-12, RF-16 FREE AIR OPERATING DATA AIR FLOW DIVIDED BY CONSUMED AIR = DELIVERY RATION (EFFICIENCY)								
MODEL	INLET PRESSURE		AIR CONSUMPTION		TOTAL AIR FLOW		DELIVERY RATIO	INLET CONNECTION NPT
	psig	kg/cm <sup>2</sup>	scfm	m <sup>3</sup> /hr	scfm	m <sup>3</sup> /hr		
RF-12	80	5.6	61	104	2,140	3,636	35	3/4 inch
RF-16	80	5.6	144	246	5,100	8,665	35	3/4 inch

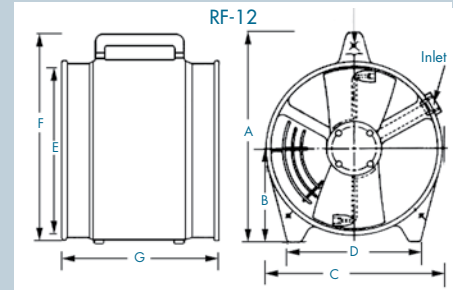

RF-12, RF-16 PERFORMANCE SPECIFICATIONS AIR FLOW THROUGH FLEXIBLE DUCT AT 80 PSIG (cfm (m <sup>3</sup> /hr))						
MODEL	DUCT Diameter	STRAIGHT LENGTH OF DUCT				
		20 ft/6 m	30 ft/9 m	40 ft/12 m	50 ft/15 m	100 ft/31 m
	inch/ mm	cfm/ m <sup>3</sup> /hr	cfm/ m <sup>3</sup> /hr	cfm/ m <sup>3</sup> /hr	cfm/ m <sup>3</sup> /hr	cfm/ m <sup>3</sup> /hr
RF-12	12/305	2,020/3,433	1,960/3,331	1,910/3,246	1,870/3,178	1,680/2,855
RF-16	16/406	4,850/8,241	4,750/8,071	4,600/7,816	4,550/7,731	4,150/7,052

RF-20, RF-24 DIMENSIONS								
MODEL	in/mm						WT lbs/kgs	
	A	B	C	D	E	BOLT SLOTS SIZE NO.		
RF-20	10.2 260	24.7 629	22.5 572	19.5 495	0.75 19	1.12 28.4	4	69 31
RF-24	11.6 294	31.2 794	30.2 768	24.0 610	1 25	1.12 28.4	4	160 73

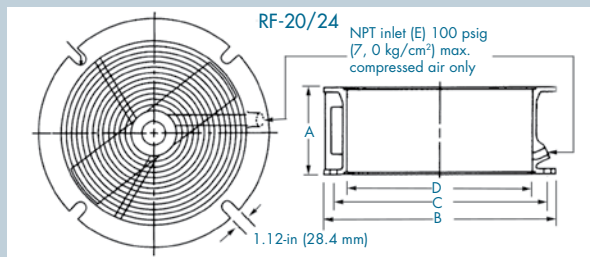

RF-20, RF-24 FREE AIR OPERATING DATA AIR FLOW DIVIDED BY CONSUMED AIR = DELIVERY RATION (EFFICIENCY)								
MODEL	INLET PRESSURE		AIR CONSUMPTION		TOTAL AIR FLOW		DELIVERY RATIO	INLET CONNECTION NPT
	psig	kg/cm <sup>2</sup>	scfm	m <sup>3</sup> /hr	scfm	m <sup>3</sup> /hr		
RF-20	60	4.2	160	271	7,000	11,893	59	3/4 in
	80	5.6	210	375	11,000	18,689	53	
RF-24	60	4.2	324	550	14,600	24,804	45	1 in
	80	5.6	400	680	16,900	28,713	42	

AIR-DRIVEN		
ITEM	PSIG	dBA
RF-12	80	104
RF-12	60	101
RF-16	80	109
RF-16	60	107
RF-20	80	108
RF-20	60	106
RF-24	80	111
RF-24	60	109



Water turbine-drive for air supply or exhaust

# COPPUS Marine Ventilators

Steam-, air- and water turbine-drive ventilators

Steam- or compressed air-turbine drive for air supply or exhaust



## MODEL/SPECIFICATIONS

### STEAM/COMPRESSED AIR TURBINE DRIVES

#### MODEL C-12A

##### SUPPLY Model

delivers 5,350 cfm (9,090 m3/hr)

##### EXHAUST Model

delivers 4,600 cfm (7,815 m3/hr)

#### MODEL C-15A

##### SUPPLY Model

delivers 8,400 cfm (14,275 m3/hr)

##### EXHAUST Model

delivers 6,500 cfm (11,044 m3/hr)

### WATER TURBINE DRIVES

#### MODEL C-12AWC

##### SUPPLY Model

delivers 5,000 cfm (8,495 m3/hr)

##### EXHAUST Model

delivers 4,700 cfm (7,985 m3/hr)

#### MODEL C-15AWC

##### SUPPLY Model

delivers 7,400 cfm (12,573 m3/hr)

##### EXHAUST Model

delivers 5,700 cfm (9,769 m3/hr)



Available adapters for:

- Butterworth deck and tank opening (pictured)
- Duct adapter

#### SAFETY PRECAUTIONS

Always be sure unit is connected to a suitable ground connection. Mounting on non-conductive adapters or free-standing use requires a bonding cable.

## DESCRIPTION

These rugged, dependable cargo tank ventilators have served the shipping industry for many years. They are ideal for on-board gas-freeing, drying and ventilation operations and are available in supply or exhaust models.

### STEAM/COMPRESSED AIR TURBINE-DRIVE MODELS FEATURES / ADVANTAGES

- Cast iron turbine housing with aluminum cover
- Bronze turbine wheel
- Grease-type ball bearings
- Cast aluminum fan and fan casing
- Stainless steel fasteners, mounting studs and protective screen

### WATER TURBINE-DRIVE MODELS FEATURES / ADVANTAGES

- Cast aluminum anodized turbine housing
- Cast aluminum anodized impeller
- Cast aluminum inlet and outlet water connections
- Grease-sealed stainless steel ball bearings
- Cast aluminum fan and fan casing
- Stainless steel fasteners and protective screen

## DIMENSIONS

MODEL	in/mm								NET* WT lbs/kgs
	A	B	C	D	E	F	BOLT SLOTS		
							SIZE	NO.	
<b>C-12A</b>	12.6 321	14.2 362	20.5 521	12.5 318	15.3 390	16.8 427	0.93 24	10	100 45
<b>C-15A</b>	21.0 533	14.2 362	22.2 565	15.3 387	20.5 521	21.5 546	1.12 28	8	120 54
<b>C-12AW</b>	14.8 376	14.2 362	22.5 572	12.5 318	15.3 390	16.8 427	0.93 24	10	63 28
<b>C-15AW</b>	16.5 419	14.2 362	24.5 622	15.2 387	20.5 521	21.5 546	1.12 28	8	77 35

\*Net weights shown are supply units.

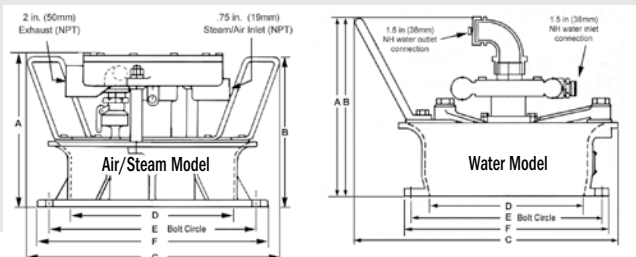



# COPPUS Marine Venturi

Lightweight, deck-mount, compressed air drive ventilator

## MODEL/SPECIFICATIONS

### OPERATING PRINCIPLE

Compressed air or steam is admitted into the Marine Venturi through a single inlet connection in the housing leading to the mixing chamber. The air from the nozzle creates a Venturi action that induces a large volume of surrounding air to enter through the inlet end. The air is then forced out through the outlet at high velocity

### DESCRIPTION

Easy to transport, rugged and maintenance-free shipboard ventilator for degassing or delivering fresh air supply to cargo tanks and other on-board confined spaces.

### FEATURES / ADVANTAGES

- Delivers 4,870 cfm (8,274 m<sup>3</sup>/hr) operating with 100 psig compressed air
- Spark-resistant, corrosion-resistant, powder-coated aluminum construction
- Weighs only 32 lbs (15 kg)
- Mates with 12 in (305 mm) Butterworth deck openings in either supply or exhaust set-up
- Built-in flange on outlet end accepts 10 in (254 mm) flexible duct, nozzles
- Stainless steel fasteners, studs and protective screen

### DIMENSIONS

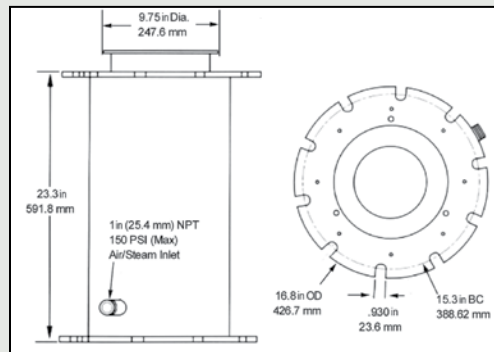

## TECHNICAL DATA

AIR-DRIVEN		
ITEM	PSIG	dBA
Marine Venturi	80	92

MARINE VENTURI SPECIFICATIONS						
INLET PRESSURE		AIR CONSUMPTION		TOTAL AIR FLOW		INDUCTION RATIO
psig	kg/cm <sup>2</sup>	cfm	m <sup>3</sup> /hr	cfm	m <sup>3</sup> /hr	
60	4.2	98	167	3,980	6,762	40.6
80	5.6	126	214	4,500	7,645	35.7
100	7	150	214	4,870	8,274	31.8

# COPPUS

# Ventilators Accessories

## DUCT CANISTER

Extend the life of your duct with the protection of a COPPUS high-density, light-weight polyethylene canister; makes transporting and storage easier and safer.

Canisters for available duct sizes:

- 8 in x 25 ft (203 mm x 7,500 mm)
- 12 in x 20 ft (305 mm x 6,000 mm)
- 16 in x 30 ft (406 mm x 9,000 mm)



## FEATURES AND SPECIFICATIONS - ALL VARIETIES

- Duct: wire supported, non-collapsible
- Quick and easy cinch belt securely fastens duct to blower housings and duct ends
- Integral rigid duct end allows easy coupling of duct without the need for separate splicer accessory
- Available diameters are 8 in (203 mm), 12 in (304.8 mm), 16 in (406 mm), 20 in (508 mm), and 24 in (610 mm); larger diameters available on request
- Available lengths: 10 ft (3 m) and 2 ft (7.5 m); duct can be coupled together for longer runs
- Temperature range: -40° F (-40° C) to +250° F (+121° C)
- Meets UL-94 specifications for flame retardant material
- Retractable for easier, safer storage
- Source capture duct: close-pitched, wire-supported and features smooth interior walls for reduced flow restriction; available in
- 4 in (102 mm), 5 in (127 mm) and 6 in (152 mm) diameters

## FLEXIBLE AIR DUCT

A large selection of flexible air duct for a variety of ventilation applications is available. Our most popular heavy-duty duct features impregnated polyester material designed for harsh, industrial environments. Other options include economical light-duty duct, source capture duct and hazardous location, anti-static duct.



## JECTAIR TRIPOD

For stationary, long-term use; rotates 360 degrees for precise direction of air-flow and accommodates 3-HP and 6-HP Jectair sizes. Installs quickly and easily with two quick-release clamps. Large feet provide stability during operation, and spring-loaded legs fold up for easy transport and storage.



## TRANSPORT CART

Heavy-duty cart allows easier transportation of VANO 175CV and 250CV ventilators (which can remain on cart during operation); includes crane-lifting loop. WEIGHT: 25 lbs (11kg)

## VANO TRIPOD

Attaches to VANO 175CV or 250CV model; makes positioning of units and direction of airflow easier by rotating 360 degrees on a 45-degree plane; spring-loaded legs fold up for easy transport and storage. WEIGHT: 19 lbs (9kg)



**For more than 90 years, COPPUS portable ventilators and cooling products have been recognized as leaders in providing reliable ventilation to meet the demands of safety and maintenance personnel around the world.**

#### **INDUSTRIES SERVED**

COPPUS portable ventilators serve a variety of industries that require a reliable fresh air supply in confined spaces for process cooling, equipment cooling and personnel cooling to increase safety and improve production.

These industries include:

**PAINTING AND COATING:** Drying and curing, fume exhaust, fresh air supply for comfort and safety

**HIGH-HEAT PROCESS STEEL:** Process cooling, personnel cooling

**ELECTRIC AND GAS UTILITIES:** Underground ventilation, equipment cooling, fume exhaust

**PAPER:** Confined space ventilation, personnel cooling

**SHIPBUILDING:** Welding fume exhaust, fresh air supply

**MARINE:** Cargo tank ventilation

**OIL REFINING:** Equipment cooling, confined space ventilation, personnel cooling

**CHEMICAL MANUFACTURE:** Fume exhaust and ventilation, personnel cooling

**BEVERAGE:** Fume exhaust, process cooling

**POWER GENERATION:** Confined space ventilation, personnel cooling

For more information about COPPUS portable ventilation products, contact us at:

**COPPUS Portable Ventilators**

Curtiss-Wright Steam & Air Solutions

37 Coats Street, Suite 200

Wellsville, NY 14895

Phone: (Int'l +1) 585-593-1234

Email: [PortableVentilator.CW@Siemensgovt.com](mailto:PortableVentilator.CW@Siemensgovt.com)

©2019 COPPUS. All rights reserved.

This brochure comprises a general overview of the products described herein. It is solely for informational purposes, does not represent a warranty or guarantee of the information contained herein, and is not to be construed as an offer to sell or solicitation to buy. Contact COPPUS for detailed design and engineering information suitable to your specific applications. We reserves the right to modify its products and related product information at any time without prior notice.

**CURTISS -  
WRIGHT**